

WIRELESS MICROPHONE SYSTEMS

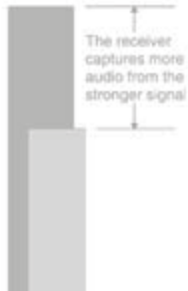

COMPARATIVE FRONT-END FILTER SLOPES

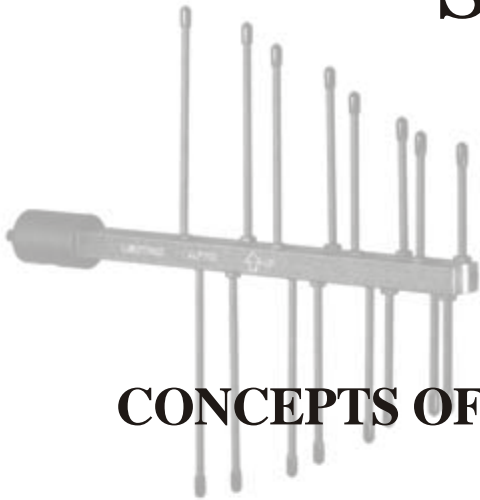
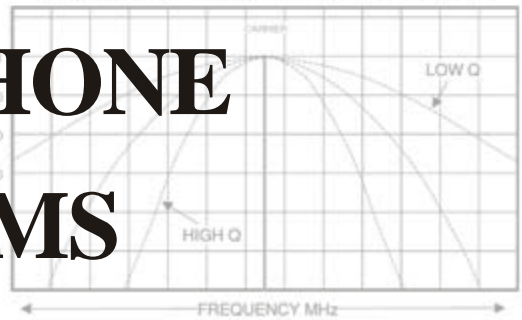

CONCEPTS OF OPERATION AND DESIGN



Preface

Wireless microphone systems are a key component in almost every broadcast, motion picture, theatrical and sound stage production, as well as corporate, religious and educational venues. As the airwaves continue to become more congested with a myriad of wireless devices and the demand for more wireless microphone systems increases, the need to understand the concepts behind the design and operation of wireless systems becomes a critical concern for professional users.

The emergence of DTV (digital television) broadcasts in North America has created an increasingly difficult environment for operating wireless systems as the available spectrum becomes more congested. DTV is also emerging in Europe, as another indicator of the spectrum crowding that the future holds in store. Considering these facts, and the ever increasing popularity of wireless microphones, intercoms, IFB systems and other radio communications devices used in almost every production, the need for a solid, technical understanding of wireless systems is at an all-time high.

This guide is intended to uncover some of the mysteries behind the operating principles of wireless systems and help the reader separate fact from fiction when selecting a wireless system for a particular application. Far too much propaganda has been published by various manufacturers, with boastful, and sometimes incredible claims about the quality of the equipment being offered. Armed with an understanding of the basic principles of wireless operation, it becomes possible to see through the maze and make intelligent choices.

Our philosophy at Lectrosonics is to build the best product we know how to make, and support it with the best service possible. This includes the publication of guides like this one, and maintaining a highly responsive attitude toward the market. Please feel free to contact us regarding any of the material presented in this guide. Your comments, suggestions and experience are extremely valuable to us.

Bruce C. Jones
Vice-president, Marketing
Lectrosonics, Inc.
March 2000

Contents

| | Page |
|--|------|
| BASIC WIRELESS SYSTEM CONFIGURATION | 1 |
| TRANSMITTERS | 3 |
| RECEIVERS | 7 |
| DIVERSITY RECEPTION | 13 |
| AUDIO SIGNAL PROCESSING | 19 |
| ANTENNAS | 23 |
| FREQUENCY SYNTHESIS | 27 |
| INTERFERENCE | 31 |
| FREQUENCY COORDINATION | 37 |
| MULTI-CHANNEL WIRELESS SYSTEMS and MULTI-COUPERS | 41 |
| SIGNAL TO NOISE RATIO | 45 |
| INTERPRETING WIRELESS MIC SPECIFICATIONS | 47 |
| EVALUATING WIRELESS MICROPHONE SYSTEMS | 51 |
| GLOSSARY OF WIRELESS MICROPHONE TERMS | 55 |
| WIRELESS MICROPHONE APPLICATIONS | 57 |

BASIC WIRELESS SYSTEM COMPONENTS



A wireless microphone system is a highly specialized combination of RF (radio frequency) and audio electronics that replaces the cable normally used to connect a microphone to another audio component.

There are basically three components in a wireless microphone system:

- 1) Microphone
- 2) Transmitter
- 3) Receiver

The term “system” refers to a combination of these three components.

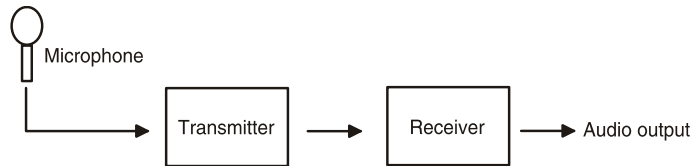

The microphone in a wireless system may be an integral part of the transmitter or it can be a separate component. In many cases, the microphone is a separate component purchased apart from the wireless system. A huge variety of different types of microphones are available to meet any application. The application normally dictates the type of receiver needed, and the microphone requirement normally dictates the transmitter model needed.

Wireless transmitters are available in three different configurations for various applications:

- Belt-pack models
- Hand-held transmitter/microphone combinations
- Plug-on models



Wireless receivers are also available in a variety of configurations for various applications:

- Compact models for field production
- Table-top models for sound reinforcement
- Rack-mount models for studio and stage

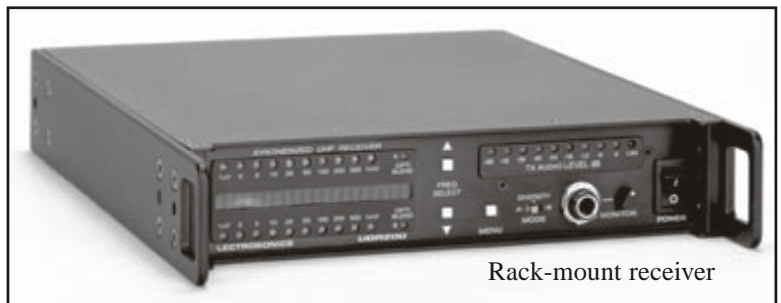

The total number of wireless systems needed in a single location often points to the need for specialized RF distribution, antennas, cabling, receiver mounting assemblies and other accessories such as the following:

- Antenna multi-couplers
- Quad-pak receiver systems
- Remote antennas and cabling
- In-line RF filter/amplifiers and splitter/combiners

Rack mount multi-coupler

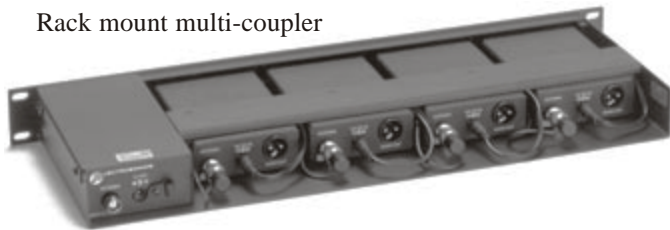

Quad Pak multi-coupler



Folding dipole antenna

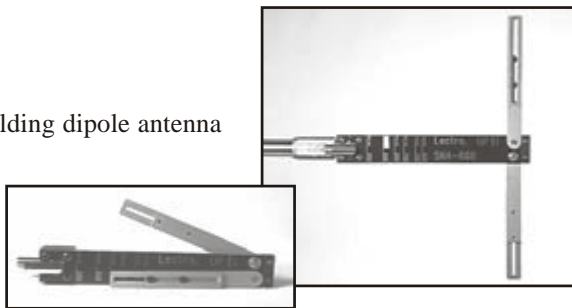

LPDA antenna
(Log Periodic Dipole Array)



SPECTRUM USAGE AND FREQUENCIES

The vast majority of high quality wireless microphone systems use a method of radio transmission called “FM” (Frequency Modulation). In FM systems, the radio signal (the carrier) is frequency modulated (the frequency is increased and decreased) by the audio coming from the microphone. Another method of radio transmission, “AM,” (Amplitude Modulation) is commonly used for communications and voice-band applications. In general, FM produces better audio than AM, so the FM principle is used almost exclusively for wireless microphones.

In the USA, wireless microphones operate in frequency bands specified by the FCC (Federal Communications Commission). Bands have been allocated for wireless microphones in the VHF spectrum from 150 to 216 MHz, and in the UHF spectrum from 470 to 806 MHz. These bands are used almost exclusively for television broadcast, except for a small portion of the VHF band between 169 and 172 MHz. DTV (digital television) broadcasts are being allocated in the UHF spectrum in what were formerly empty channels. The upper and lower parts of the UHF spectrum are also being broken up and re-allocated to make room for additional services. As the available spectrum space for wireless microphones continues to shrink, the need for higher quality wireless microphone systems increases dramatically.

High powered television broadcast signals on adjacent channels can render a previously working wireless system virtually useless. High performance receivers and multi-couplers, and specialized antennas and cabling equipment are required for any professional application to meet the constantly increasing demand for more and more wireless microphone systems.

As you can well imagine in this “digital” world, extensive engineering effort is also being applied to develop digital modulation techniques for wireless microphone applications. The hopes are that digital wireless systems might alleviate some of the problems encountered with the present analog FM systems that now exist, and produce equal or higher quality audio performance. It is much too early (as of the date of this writing) to delve into the intricacies of comparative digital radio techniques, so this guide is focused on the FM principle. Present digital technology has produced good quality cellular telephone systems, but the limited audio bandwidth of even the highest quality telephone system cannot produce the audio quality needed for even minimal wireless microphone applications.



In-line RF filter/amplifier

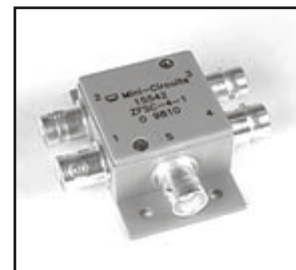

Passive 4-way
RF splitter/combiner

TRANSMITTERS

OVERALL CONFIGURATIONS

Transmitter designs can be grouped into three basic types:

“**Belt-pack**” lavalier models for use with lapel mics, instruments, mixers, tape decks, etc.

“**Plug-on**” models for use with hand-held mics, boom poles, mixers and other equipment with XLR connectors.

“**Hand-held**” models with an integral microphone capsule, primarily for hand-held use.



Belt-pack

Belt-pack transmitters can be constructed of metal or plastic. They can be designed to utilize the microphone cord or input cable as the antenna (common in VHF designs), or use a “whip” antenna. Input gain must be adjustable over a wide range to accurately match the enormous variations in output levels from microphones and other equipment.

Most belt-pack transmitters operate on alkaline or lithium 9 Volt batteries, and include a battery status indicator of some type. The best designs offer adequate warning of low battery condition to allow time to plan for a battery change.

The battery door design is also an important consideration. If the battery door detaches from the transmitter, it can get lost or broken, rendering the system unusable. The battery compartment must accept the wide variety of different brands of batteries available.

The belt clip is oftentimes a weak point in many belt-pack designs. It should provide a secure attachment, but also be easily removable for concealment in applications such as in motion picture or stage productions.



Plug-on

“Plug-on” transmitters adapt any microphone with an XLR connector to wireless operation. Their usefulness is evidenced by the increasing number of models offered by various manufacturers. Professional models typically operate on alkaline or lithium 9 Volt batteries, and provide a wide input adjustment range to accommodate the wide variety of microphone types. The mechanical construction, especially the input coupler, is the key to what makes this type of transmitter most useful for professional applications.



Hand-held

Hand-held transmitters with integral microphone capsules are offered by almost every wireless mic manufacturer. The most popular applications for hand-held transmitters are in the musical performing arts. A hand-held transmitter must be comfortable and secure in the user’s hand to guard against being dropped. It must provide the necessary level and frequency adjustment controls, yet the controls must be concealed or recessed to prevent accidental mis-adjustment during normal handling.

Frequency selection controls are provided in various manners in synthesized transmitters, ranging from pushbuttons with LCD readouts to concealed rotary controls. The example shown here provides two rotary switches to select one of 256 different frequencies over a 25.6 MHz bandwidth. The left-hand switch changes the frequency in 1.6 MHz steps and the right-hand switch provides 100 kHz steps. Each switch has 16 positions, providing a total of 256 different frequencies.

USER CONTROLS AND INDICATORS

With regard to all types of transmitters, the user controls and indicators are the practical features on various transmitter models which can “make or break” a design as it serves a specific application. For example, if a transmitter is to be used by a variety of different users, it is imperative that it offer an accurate means of compensating for the different voice levels of the various users. Proper gain adjustment is critical, since this will determine the ultimate signal to noise ratio of the system. Without a visual means of monitoring the audio level, it is almost impossible to correctly adjust the input gain to the transmitter. Although this adjustment can be made by viewing level meters on the receiver, it is much more practical to monitor the levels at the transmitter since, in many applications, the receiver is not within view from the transmitter location.

A common problem in some designs relates to function switches that are too easily moved. This can create numerous problems, including the complete “shut down” of the system during a performance. The location and physical adjustment of operational switches will determine the usefulness of a transmitter for a specific use. For example, a public speaker may require that the transmitter be muted easily, even when the transmitter is worn underneath clothing. In this case, a switch that is hard to reach can make it difficult to operate. In many stage productions the sound company may require that the user has no means of changing any switch or control on the transmitter. These two examples are mutually exclusive.

Lectrosonics hand-held transmitters offer internal switches that defeat the external switches, which allows the transmitter to be configured for any application.

ANTENNA CONFIGURATIONS

The antenna configuration is another consideration in comparing different transmitter designs. If every user of a wireless system could live with mounting a metallic “tree” on their shoulder, or on top of their head, transmitters could radiate RF energy very efficiently, providing incredible operating range and few (if any) drop outs. Few people, however, would wear something like that in public. So, in reality, the transmitter antenna must be inoffensive or invisible altogether, yet it must still radiate sufficient RF energy for the receiver to operate normally. The only reason that wireless mic systems work as well as they do is the fact that the operating ranges are generally fairly short (several hundred feet, or less) and adequate RF power output and modulation (deviation) is allowed by the FCC to let the systems operate with an acceptable signal to noise ratio.

A common problem with belt-pack transmitter antennas is that they are normally worn against the body, especially when they are concealed in costumes. By placing the antenna in contact with the user’s body, much of the radiated RF energy can be lost before it can get out into the air, which reduces the range of the wireless system. When used with portable mixers in over shoulder bags for field production, the transmitter can be positioned away from the body and other equipment to allow the maximum radiated power and operating range.

In the case of hand-held transmitters, the unit is normally held out away from the users body, with the user’s hand actually becoming part of the antenna. A protruding “rod” antenna moves the antenna out of direct contact with the user’s hand, but

it can be visually distracting and vulnerable to breakage. Hand-held transmitters designed with internal antennas eliminate this vulnerability and are generally the most visually acceptable.

Plug-on transmitters use the metal housing of the transmitter body as the antenna, with the attached microphone and even the user’s hand forming the other half of an ideal “dipole” arrangement. At UHF operating frequencies, the length of the housing is very close to an ideal 1/4 wavelength, which provides maximum radiated power and exceptional operating range.

INPUT GAIN ADJUSTMENT

This is an area where wide variations will be found in transmitter designs from different manufacturers. Simply stated, setting the proper input gain is the most important adjustment on a wireless microphone system, yet it is often overlooked in many designs. Set too low, the signal to noise ratio of the system will suffer. Set too high, severe distortion and/or compression of the dynamic range will occur. Adjusting the transmitter input gain is very much like setting the record level on an analog tape recorder.

It is important to consider the features and controls offered on any wireless transmitter that enable accurate gain adjustment. LEDs on the transmitter can be used as well as some sort of metering on the receiver to adjust the input gain. It is best to have indicators on both transmitter and receiver, however, so accurate level monitoring is possible from either the transmitter or receiver location to accommodate a variety of applications.



Typical transmitter gain control with LEDs for adjustment.



Receiver front panel LED strip for monitoring.

OUTPUT POWER

The maximum allowable RF output power produced by the final amplifier in the transmitter is regulated by the FCC. For example, in the VHF spectrum from 174 to 216 MHz the maximum allowable transmitter output power is 50 mW. In the UHF band maximum allowable transmitter power is 250 mW.

Higher output power from the transmitter helps overcome drop out problems and increases operating range, but the sacrifice is shorter battery life. The actual effective radiated power is heavily affected by the individual transmitter antenna, so a higher output power does not necessarily mean greater operating range.

Most high quality VHF transmitters produce the allowed 50 mW, for reliable operating range and reasonable battery life. There are some VHF designs offered by some manufacturers, however, that produce only 30 mW or less, yet the published specifications for these models make it appear that they are full power designs.

UHF transmitter output power varies much more widely from one brand to another than VHF units. The maximum allowance of 250 mW in the UHF spectrum is useful when maximum operating range is the prime concern. The trade-off is shorter battery life. 100mW is commonly chosen for UHF transmitters as a good balance between operating range and battery life.

Some UHF models are advertised to radiate as much as 150 mW when, in reality, they actually only produce 30 or 40 mW. There is no excuse for any manufacturer to publish incorrect information about their product simply to disguise the fact that it may not meet the competition, or may have some inherent design problems. It is also interesting to note that these same manufacturers often forget to publish battery life or power consumption in their specifications.

POWER SUPPLIES AND BATTERY LIFE

Battery life is a common concern in considering the use of any transmitter for a particular application. It is a critical concern in applications such as motion picture production and theatre where the transmitter is often concealed underneath elaborate costumes and changing a battery could be a major ordeal. An accurate transmitter battery status indicator should be provided on the transmitter and on the receiver for this type of application.

A 9 Volt alkaline battery (the most commonly used for wireless mic transmitters) starts off slightly above 9 Volts and then drops down gradually over the life of the battery. High quality transmitters include internal voltage regulators to keep the transmitter stable as the battery voltage drops.

Extended operating time can be achieved without sacrificing output power with a design that allows the circuitry to continue to operate at lower battery voltage levels. The best designs continue to operate at battery levels down to about 6.5 Volts.

High-end wireless systems normally provide a transmitter battery status indicator on the receiver to warn the user well before the transmitter ceases to operate.

RECEIVERS

OVERALL CONFIGURATIONS

The application for a wireless microphone system dictates the type of receiver required. In general, receivers can be sorted into a few broad categories:

- Compact models for field production on cameras, in portable bags or on sound carts; also includes multi-channel assemblies for motion picture production
- Table top models generally used for “stand alone” applications in sound reinforcement
- Rack mount models for high-end studio, stage and mobile production vehicles

The differences between these basic groups have to do with the physical configurations, powering options, RF performance and audio performance. Within each of these groups, a wide variety of different models are offered by dozens of manufacturers, over a very broad price range.

FIRST A FEW BASICS

In order to make comparisons between various different receiver designs, it is important to have at least a basic understanding of receiver design. With a basic understanding of the various sections of a receiver in mind, the differences in cost and performance offered in two different models will become more clear. This will help significantly in evaluating systems for specific needs and making valid purchasing decisions.

FM receivers for wireless microphone systems are super-het (super heterodyne) designs. The “super-het” process involves generating a high frequency signal inside the receiver and mixing or “heterodyning” the signal with the incoming carrier signal. When the signals are mixed together, the intermodulation produces “sum” and “difference” signals. The purpose of mixing the signals is to derive a lower frequency signal which can then be processed with conventional circuitry. Through filtering, the “sum” is rejected, passing only the resulting “difference” signal (the “IF” or “intermediate frequency” signal). The IF signal is converted to audio in the detector stage, followed by some type of audio output amplifier. Thus, a radio signal is converted into an audio signal.

The process sounds simple when described like this, but the reality is that designing a truly high quality FM receiver is a bit of a “black art.” Super-het receivers can be “single conversion,” “double conversion” or even “triple conversion.” The diagrams below depict highly simplified single and double conversion FM receivers. A triple conversion design simply has a third oscillator and mixer. The drawings depict only the major stages in each of these receiver types for the purposes of this discussion. In reality, each of these stages usually consists of a number of separate circuits and sub-circuits, some providing a basic function, with others providing additional correction or control. As you can well imagine, each stage in the receiver provides a challenge to the design engineer to meet the performance and cost criteria of the design. The mechanical design of good receiver must also be integrated with the electrical aspects, in order to provide the necessary shielding around some sections of the circuitry.

RECEIVER FRONT-END DESIGN

The front-end of the receiver is the first step in a chain of filtering, gain and conversion processes. The front-end is basically a bandpass filter operating at the carrier frequency of the wireless system. The job of the front-end is to reject high powered RF signals above and below the operating channel and to provide strong “image rejection.” (“image rejection” is explained later in this chapter) The front-end can consist of either simple low cost coils to provide simple filtering for a low cost design, or it can consist of helical resonators or tunable ceramic resonators for high performance designs.

A simple coils in the front-end section provide only broad band filtering, which is oftentimes not enough to guard against interference from high powered RF signals close to the operating frequency of the wireless system. Television broadcasts are the most common high powered source of interference for UHF wireless microphone systems. As DTV (digital television broadcasts) fills up formerly empty spectrum space, the need for high quality, narrower front-end sections increases. Helical and tunable ceramic resonators, used in multiple stages with high quality amplifiers, are the best means of reducing or eliminating interference from television broadcast signals.

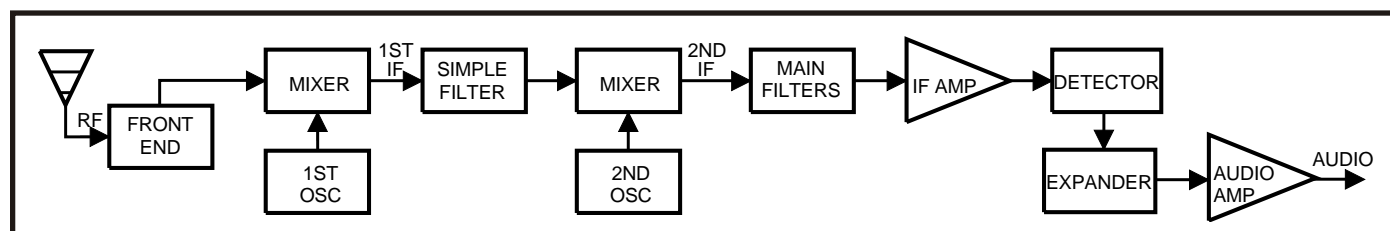
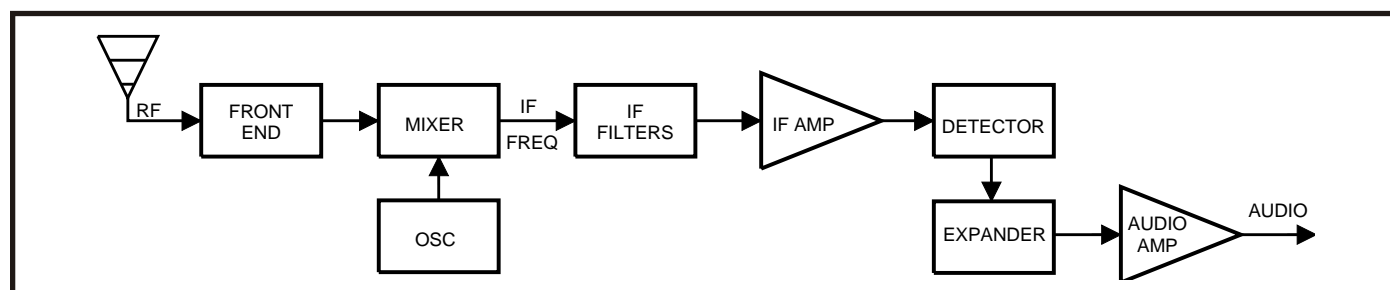

COMPARATIVE FRONT-END FILTER SLOPES

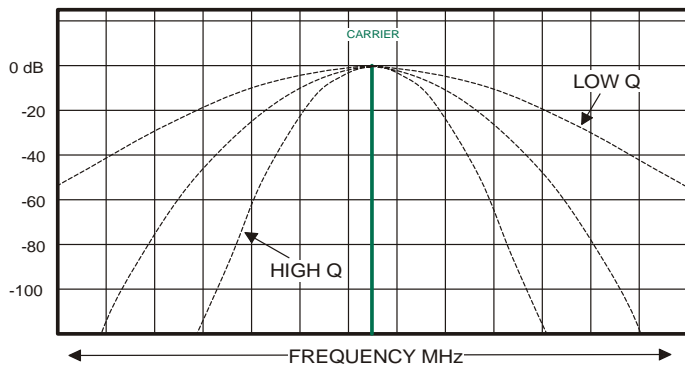

The difference in performance between various front-end designs is primarily two areas:

- Selectivity
- IM (intermodulation) Rejection

Selectivity is expressed by the amount of signal rejection above and below the operating channel the front-end will provide. The comparative curves in the drawing below illustrate the slopes of various types of front-end filters. The steeper the filter slopes, the stronger the rejection of energy on adjacent frequencies. Different types of front-end components (coils, resonators, etc.) produce varying filter slopes, but all high quality receivers are designed with multiple stages of whatever components are used in the design. These multiple stages increase the filter slope dramatically, but do cost more.

Intermodulation is the mixing of signals to produce new signals. For example, when two signals are mixed into an active circuit such as an amplifier, the output of the amplifier will include both signals, plus the sum and difference of the signals. The sum and difference signals are called “IM products.” Third order IM simply means that the second harmonic (second order) of one of the original signals (Fa) mixes with the fundamental (first order) of the other signal (Fb) to produce another signal (Fc).

$$\text{Or: } 2(Fa) - Fb = Fc$$

Preventing third order IM is most important because it produces strong interference products and the two signals that produce the third order IM can be arbitrarily close to the desired carrier. If the interfering signals do happen to be close to the carrier frequency, then the front end filtering is largely ineffective. The only way to reject this kind of close in IM interference is to have high overload point amplifiers and mixers in the receiver.

For example:

Given two frequencies of 645 and 650 MHz

then

$$645 \text{ MHz} \times 2 = 1290 \text{ MHz}$$

and

$$1290 \text{ MHz} - 650 \text{ MHz} = 640 \text{ MHz}$$

A receiver at 640 MHz will pick up direct interference from two transmitters on 645 and 650 MHz. Even spacing like these three frequencies is always taboo in wireless microphone systems.

IM performance is rated with a specification called “third order intercept.” This spec is a number expressed in dBm that refers to the power of interfering signals needed to cause the receiver to produce distortion (IM) at the same level as the interfering

signals inside the receiver. Two signals are injected into the receiver to produce third order IM on the carrier frequency of the receiver and the level of the IM product is measured. Through several different measurement techniques, an accurate calculation can be made as to the input level required to produce this effect. The rated third order intercept number is an excellent means of measuring the receiver’s IM rejection.

The type of amplifier used has a large effect on the third order intercept performance of the receiver. Amplifiers with excellent third order intercept performance require lots of power, which poses a problem with a receiver designed for battery operation. The narrower the front-end filters (which cost more), the less apt the receiver is to pick up signals that could generate IM.

IMAGE REJECTION

Image rejection is a major performance measurement of a receiver. There are two signal frequencies which will combine with the local oscillator to produce the same IF. One is the desired signal from the transmitter and the other is the frequency which is the same “distance” from the local oscillator as the desired signal, but in the opposite direction. RF energy on or near the image frequency of a receiver can be a major source of interference.

IMAGE REJECTION vs. FRONT-END SLOPE

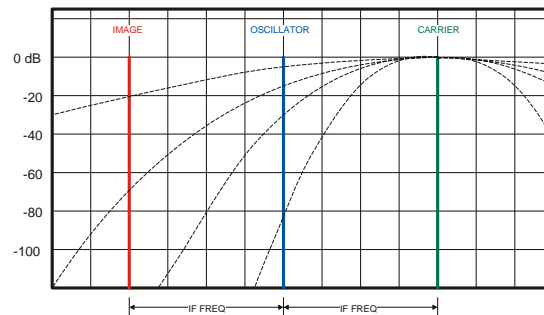

It is not unusual that the image frequency of a wireless microphone system operating on an empty TV channel could be at the same frequency as another television station signal. This will produce interference problems for all but the most selective front-end designs. Sharp front-end filtering rejects energy on the image frequency to keep it from entering the receiver.

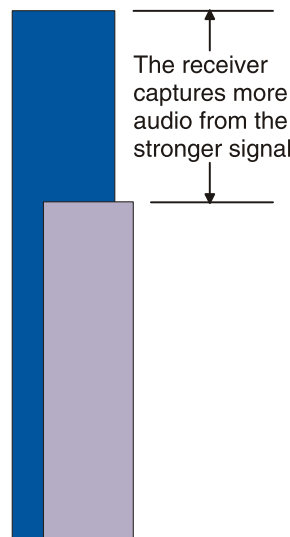

CAPTURE EFFECT

FM receivers benefit from an effect called “FM capture.” This refers to the fact that an FM receiver will capture more audio from a strong signal than from a weaker one. The audio present in the stronger signal will be dominant in the audio produced at the receiver output. The weaker signal, however, can still increase the background noise and make dropouts occur more often. A “weaker signal” in this sense could be another wireless transmitter signal, or broadband background noise.

RF MIXERS

The mixer in a receiver combines the incoming RF signal with the oscillator signal, producing “sum” and “difference” signals. The “difference” signal is at the desired IF frequency. Low cost RF mixers produce spurious signals (harmonics) along with the desired sum and difference signals. If spurious signals occur near the IF frequency of the receiver, they cannot always be rejected by the IF filters and can cause noise or distortion in the final audio output. High quality RF mixers produce only a sum and a difference signal, without harmonics. The “sum” is so high in frequency that it is completely rejected by the IF filters following the mixer, leaving only the desired “difference” signal for subsequent processing.

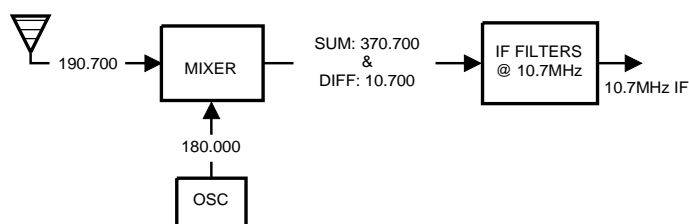

The mixer must also have a very high overload threshold. Overload can occur when the total RF energy being fed into the mixer exceeds its capacity. Sharp front-end filtering reduces this problem, but strong signals a few MHz away from the carrier frequency can still get through the front-end and cause overload in the mixer. The most effective approach in front-end design is to include only enough gain between each filtering stage to compensate for the required losses. The basic idea is to apply all the required filtering before any significant gain is applied to the signal to keep noise and interfering signals at a minimum.

IF FILTERING

The IF filtering in a receiver produces the real “selectivity” in the receiver. Standard multi-pole ceramic IF filters offer a bandwidth of about 300 kHz. Six-pole crystal IF filters offer a bandwidth only 45 to 50 kHz wide. The narrower the filtering in the IF stage, the better. Crystal filters cost many times more than ceramic filters, but the performance is worth it in many applications where interference is a serious problem.

Narrow-band crystal filtering, however, demands that the frequency cannot drift, which requires a very temperature stable oscillator. Low cost, “wide-band” receivers can get away with “drifty” oscillators, since the resulting IF frequency will still be within the limits of the IF filters.

A third filter type that is beginning to see wider use in receivers is the SAW filter (Surface Acoustic Wave). These filters use surface waves on a quartz or other piezoelectric material to transfer RF energy from input to output, and use the precise spacing of interdigitated fingers on the surface to pass some frequencies and filter out all others. SAW filters offer precise filtering at higher than usual IF frequencies and also provide minimal phase shift (group delay) that is difficult to achieve with other methods. This makes the designer’s job a bit easier as wireless microphones use higher and higher UHF frequencies, but while they have higher selectivity, they are more expensive than some other types of filters.

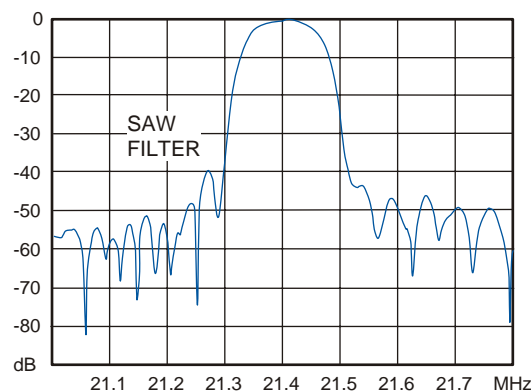
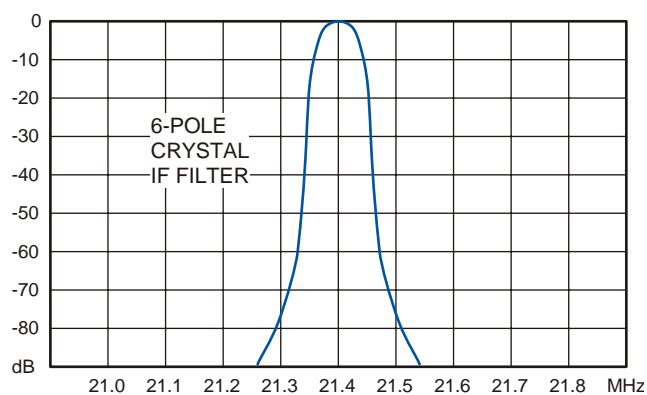
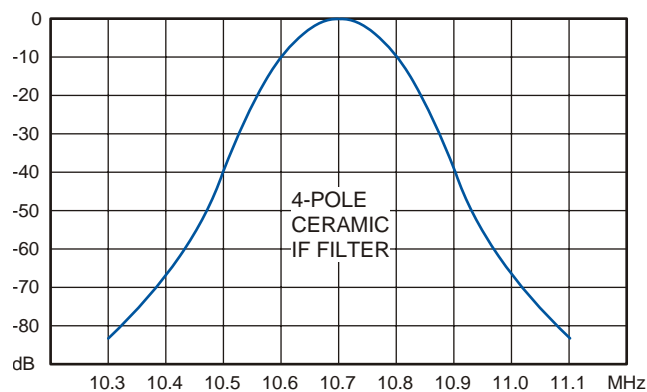

Without question, the best interference rejection occurs with a stable oscillator and narrow-band IF filtering, as is produced with crystal filters. The only drawback to crystal filters, however, is they have a slightly higher distortion than ceramic and SAW filters when the signal is highly modulated. For this reason, you will often find ceramic or SAW filters rather than crystal filters used in high-end receivers where the primary concern is audio fidelity.

FM DETECTORS

The discriminator or detector in a receiver is the circuitry which converts the frequency modulated (FM) radio signal into an audio signal. There are several different circuits used by various manufacturers, but all detectors in wireless microphone receivers are based upon two basic approaches:

- 1) Quadrature Detector
- 2) Pulse Counting Detector

A **quadrature detector** is a circuit that utilizes phase shift to generate a varying DC voltage, producing the audio signal. The output of the IF section is amplified to produce almost a square wave. The signal is then split into two signals, with one of them routed through a phase shifting circuit. The signals are then mixed back together with the phase of one signal delayed by 90 degrees (the signals are in quadrature). The average level of the resulting signal is directly related to the phase shift (frequency variation) of the radio signal.

A digital **pulse counting detector** is a different, but much more effective method of converting an FM radio signal into an audio signal. The counting detector generates a stream of fixed-width DC pulses at intervals controlled by the frequency of the radio signal.

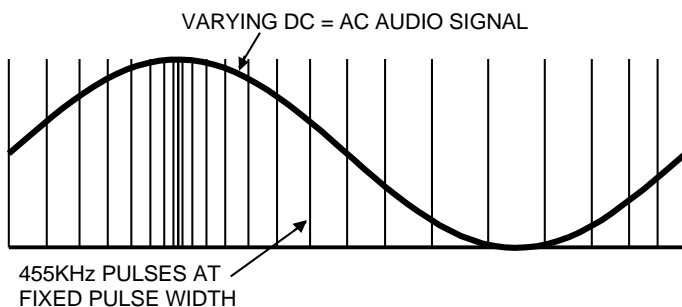

As the frequency increases, the pulses are spaced closer together. As the frequency of the radio signal decreases, the pulses are spaced more widely. The average voltage level of the pulses in any given time interval will fluctuate in direct proportion to the frequency of the FM signal, producing a varying low frequency voltage (the audio signal).

Counting detectors normally operate at frequencies under 1 MHz, which means that they can only be effectively used in double conversion receivers. Trying to use a counting detector in a single conversion receiver would mean that the oscillator frequency would be very close to the carrier frequency, in order to mix down to a frequency low enough to allow the detector to operate without distortion (remember how the superhet design works). A first IF frequency close enough to the carrier frequency (several hundred kHz) to allow mixing down to a frequency of several hundred kHz would not allow adequate front-end filtering for the necessary image rejection (image rejection is discussed in the following paragraphs). Counting detectors offer extremely high temperature stability and inherently high AM rejection. Counting detectors are used in only the most advanced wireless receiver designs, as of the date of this writing.

STABILITY AND THERMAL DRIFT

A second benefit of a double (inductors and capacitors) in a quadrature detector circuit vary for any reason (usually temperature), serious distortion will be produced in the audio signal. For example, in a single conversion receiver operating with an IF at 10.7 MHz, a drift of only 0.5% in the tuning of the detector circuit would result in the detector being over 53 kHz off frequency. This is enough to cause serious distortion. In a double conversion receiver with a second IF at 1 MHz, the same shift of only 0.5% in the detector will result in only a 5 kHz shift in the tuning. Thus, a 1 MHz detector has better than a 10:1 advantage over a 10.7 MHz detector with respect to thermal drift.

So, why are all receivers not double conversion designs with a detector at 1 MHz? For starters, double conversion receivers involve a lot more parts and cost more to build and align, since there are two oscillators and two sets of IF filters. Secondly, two oscillators can produce a lot more internal intermodulation problems, since the oscillators can leak into other circuitry and even interact with each other, causing all kinds of “strange” effects. Properly designed double and even triple conversion receivers, although more difficult to design, offer better performance in the final analysis.

COMPANDORS (expanders)

The expander which follows the detector in a receiver must be a perfect “mirror image” of the compressor in the transmitter. Its purpose is to complete the noise reduction companding process by doubling the dynamic range of the audio signal, reversing the compression applied in the transmitter. The audio dynamics are compressed in the transmitter at a 2 to 1 ratio. The expander in the receiver expands the audio dynamics by the same ratio, to restore the original audio signal dynamics. (Companders are discussed in more detail in the section entitled “AUDIO SIGNAL PROCESSING.”)

AM REJECTION

The primary method of improving the AM rejection of a receiver is to apply heavy limiting just ahead of the detector. The limiting converts the signal into almost a pure square wave so that AM level fluctuations will not change the shape of the waveform feeding into the detector.

Some types of detectors also provide AM rejection. A quadrature detector has no inherent AM rejection, whereas a pulse counting detector does provide additional AM rejection.

AUDIO OUTPUT SECTION

The audio section of a receiver must provide ultra low noise gain, with minimal distortion. It must also provide the correct output connectors, balanced or unbalanced configuration, and output levels for the intended application. Low cost receivers typically provide only a single output, generally unbalanced as well. High quality, multi-purpose receivers will offer several outputs with various connectors at different levels for use with a wide variety of sound and recording equipment.

SQUELCH TECHNIQUES

The “squelch” circuitry in a receiver is employed to mute the audio output when the matching transmitter is turned off, or when signal conditions are too poor to produce a usable signal to noise ratio. Several different methods are used:

- 1) Fixed RF level threshold
- 2) Variable level controlled by HF audio noise
- 3) Pilot tone control signal
- 4) Digital code control signal
- 5) Microprocessor controlled algorithm (SmartSquelch™)

Two opposite conditions require different squelch activity:

- 1) Close operating range with a strong average RF level
- 2) Distant operating range with a weak average RF level

At a close operating range with a generally strong RF level, an ideal squelch would be aggressive and mute noise caused by multi-path dropouts without allowing any noise to be produced in the audio signal. The problem with this approach is that an aggressive squelch will reduce operating range significantly.

At longer operating distances with a lower average RF signal level, an ideal squelch would be less aggressive and allow the RF signal to dip closer to the noise floor in order to extend operating range. This approach, however, can allow brief “noise-ups” at close range caused by multi-path signal conditions.

A **fixed RF level** squelch systems monitor only the incoming signal level to determine the need to squelch. While the squelch threshold is often adjustable in this type of design, determining an optimum setting is difficult at best, since the average RF level in any given situation is almost impossible to predict. The receiver can also be falsely triggered by interference when the matching transmitter is turned off

A squelch system that utilizes **HF audio noise** to control the squelch threshold is effective at muting the receiver when the transmitter is turned off. This approach also assumes that a dropout is preceded by a build up of high frequency audio noise. While this type of squelch is fairly effective in most cases, it can also be “fooled” by audio containing a large amount of high frequency content such as jingling car keys or coins.

A **pilot tone** controlled squelch system normally uses a continuous supersonic audio signal generated in the transmitter to control the audio output of the receiver. The receiver must be more sensitive to the pilot tone signal than the RF carrier to avoid inadvertent squelching when the carrier is weak, yet still strong enough to produce useable audio. This approach is highly reliable in muting the receiver when the transmitter is turned off, but it does not address the issue of strong and weak RF signal conditions when the transmitter is close or at a distance.

A **digital code squelch** technique utilizes a supersonic audio signal containing a unique 8-bit code generated in the transmitter to signal the receiver to open the audio output when the transmitter is turned on. The code is repeated several times at turn on to ensure that it is picked up by the receiver. At turn off, the transmitter first emits another code to signal the receiver to mute the audio, then after a brief delay, shuts down the transmitter power. A different code is used in every system to avoid conflicts in multi-channel wireless systems. This approach is highly effective at keeping the receiver quiet when the transmitter

is off, and eliminates noise at turn-on and turn-off, but it does not address the issue of strong and weak signal conditions.

A unique technique called **SmartSquelch™** is employed in some Lectrosionics receivers. This is a microprocessor controlled technique that automatically controls the squelch activity by monitoring the RF level, the audio level and the recent squelching history over a time period of several seconds. The system provides aggressive squelch activity during strong RF signal conditions to completely eliminate noise caused by multi-path conditions at close range. During weak RF signal conditions, the system provides less aggressive squelch activity to allow maximum operating range by taking advantage of audio masking to bury background noise.

COMPUTER INTERFACE

With the advent of microprocessor control, a powerful tool is available to assist in identifying RFI and find clear operating spectrum. Software supplied with the Lectrosionics UDR200B receiver provides a graphical display of all internal settings and status, as well as adjustment of a variety of operating modes. Utilizing an RS-232 compatible PC interface for the Windows® operating system, the receiver can be also used to perform a “site scan” when setting up a wireless system in a new location.



The lower section of the display provides a graphical, scanning spectrum analyzer for conducting site surveys. During scanning, the receiver is tuned in steps across its tuning range and markers are placed on the screen to indicate the frequency and signal strength of signals found.



For use with multi-channel wireless systems, the software also provides a summary screen showing the most critical, real-time activity for either 25 or 42 receivers simultaneously. RF and audio levels, internal temperature and the status of batteries in the transmitters are all shown in a multi-colored display.

DIVERSITY RECEPTION

The term “diversity” is one of the most widely misunderstood concepts of wireless systems. This word stems from the root word “diverse,” meaning “not correlated.” As it applies to wireless microphone receivers, the term simply refers to the use of two antennas to eliminate “dropouts” caused by multi-path phase cancellations (multi-path nulls).

A multi-path null is illustrated below. In this example, the signal from the transmitter reaches the receiver antenna via a direct path and a reflected path. The reflected signal path is a bit longer than the direct path, causing the two signals to be out of phase when they mix together at the receiver antenna. The resulting weak signal causes what is known as a “dropout.”

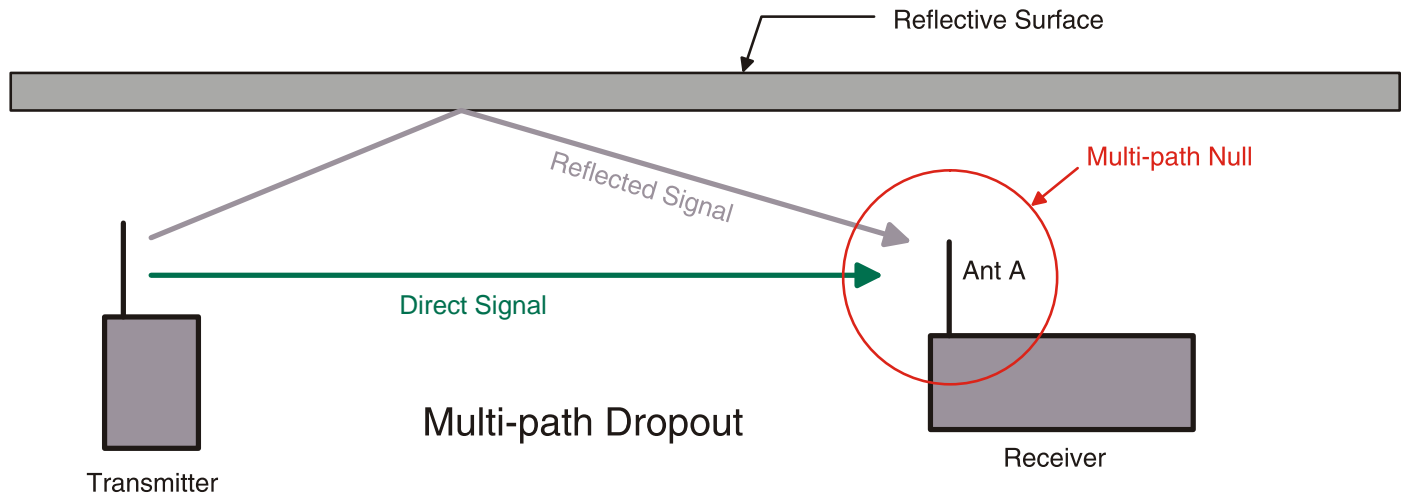

The most common type of dropout might more appropriately be called a “noise up,” where the receiver audio output remains open during a multi-path null, and brief hiss, clicks, pops or other noise can be heard momentarily along with the audio. A complete loss of the audio can also occur if the multi-path null is deep enough to cause the receiver to squelch. VHF dropouts usually sound more like a momentary swishing or hissing sound, sometimes along with a buzzing sound. UHF dropouts are more shorter in duration than VHF due to the higher frequency and shorter wavelength, sometimes sounding more like a pop or click.

Multi-path conditions that cause dropouts are very common indoors, since the output of a wireless transmitter radiates in all directions and bounces off of many types of surfaces in the room. In reality, a wireless system operating in a room will be generating perhaps hundreds of reflections around the room, but the system continues to operate since the direct signal is normally stronger. Metal is an especially good reflector, so multi-path conditions also occur outdoors, since the transmitter signal can be efficiently reflected from cars, trucks, trailers, metal building surfaces, etc.

Dropouts occur when the transmitter and receiver antennas are in a particular location relative to each other. Moving the transmitter or receiver to a different location can oftentimes reduce or eliminate the dropouts. Other objects that move around the room, like people’s bodies, also alter the reflected and direct signals and can make dropouts either more or less prevalent.

The wavelength of radio signal carriers at VHF frequencies ranges from about 5 to 6.5 feet long. At UHF frequencies, the wavelength ranges from about 12 to 20 inches. The point is that the “dropout zone” (the location where a dropout occurs) will be larger at VHF frequencies than at UHF frequencies, so antennas have to be moved farther with a VHF system than with a UHF system to alleviate dropouts. This also means that locating and being able to identify a dropout zone during a walk test is a bit easier with a VHF system than with a UHF system.

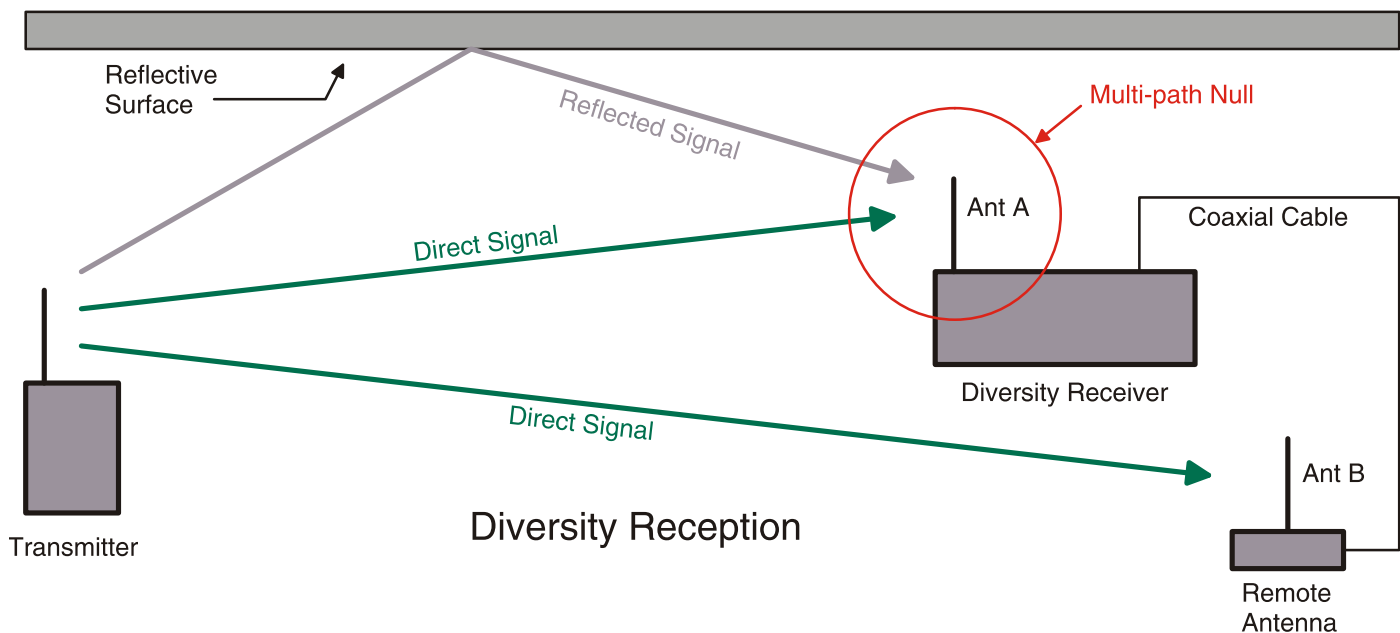

In this simplified illustration of diversity reception, the signal arriving at antenna A is largely cancelled by a multi-path null, leaving little signal left for the receiver. The signal at antenna B remains strong and provides adequate signal for the receiver to produce a usable audio signal to noise ratio.

Note that the illustration shows antenna B as a “remote” antenna connected with coaxial cable. The spacing between the antennas must be at least $1/2$ wavelength of the operating frequency to ensure that the antennas are receiving uncorrelated (“diverse”) signals to gain the full benefit of diversity reception.

Imagine what would happen if antenna B was also mounted on the receiver. If the system was a VHF design, there would be a strong chance that the multi-path null would occur simultaneously at both antennas. What would be the benefit of trying to switch back and forth between two antennas that are picking up the same signal? The difference between the two signals would be either nonexistent or so minimal that it would not have any effect on the reception. At UHF frequencies with the shorter wavelengths, there might be enough space between the antennas to achieve some benefit of diversity reception when two antennas are mounted on the receiver.

Diversity circuitry implemented in a high quality receiver with excellent sensitivity will reduce or eliminate multi-path dropouts, and in some cases, increase operating range. The improvement in reception will vary depending upon the diversity methodology chosen by the designer.

The type of diversity reception circuitry chosen in the receiver design includes a number of considerations, including cost, size and weight, performance and the practicality of each circuit type for a given application.

Cost is the major criteria for designs driven primarily by market considerations. Size and weight are most important in receivers designed for field production. Performance is the primary focus in high-end studio and stage receivers. In designs aimed at motion picture production, the price of the wireless equipment is far out-weighted by the cost of perhaps even a single day of production, so audio and RF performance is the primary concern.

How the incoming signals from two different antennas are handled after they enter the receiver is what makes the difference between a good design and one that has problems. Using diversity reception makes little sense unless the receiver is a high quality design to begin with. A low sensitivity diversity receiver will often have problems in an environment where a single antenna, high performance receiver will operate without noise or dropouts. “Diversity” reception of any type will do little, if anything, for a low performance receiver. In fact, it can even make matters worse.

The following pages illustrate and discuss several different techniques used for diversity reception in various designs with varying degrees of success.

PASSIVE DIVERSITY

This is simply the addition of a second antenna to a single receiver, placed $\frac{1}{2}$ wavelength or more away. This can be accomplished easily with an outboard combiner and a second antenna. Two combined antennas will gather more RF signal and can reduce dropouts to a small degree.

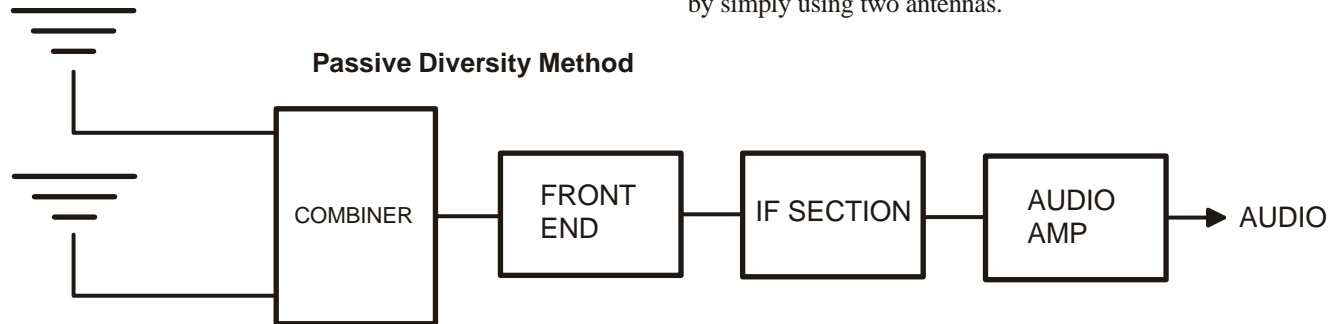

The logic behind using two antennas as opposed to one is simply “playing the odds.” The chances of a multi-path “null” occurring at both antennas at the same time are perhaps less, but when both antennas have a good signal, but the signals are out of phase with each other, dropouts will still occur. Real world tests have shown that there is no real improvement in the prevention of dropouts by simply using two antennas.

ANTENNA PHASE SWITCHING DIVERSITY

The primary advantage of this technique is small size, which explains why this method is used in compact receivers designed for field production. Two antennas are mixed to feed a single receiver, with a phase reversal switch added to the input of one of the antennas. When signal conditions deteriorate, the phase of one of the antennas is reversed and logic circuitry then determines whether or not the switching action has improved the signal to noise ratio or not, and decides whether to latch in that position or switch and sample again. The antenna phase will remain in the better position until the signal deteriorates again, when the process is repeated.

The logic underlying this approach is this:

- 1) If either antenna has a strong signal, reception will be OK.
- 2) When both antennas have an in-phase weak signal, the signals will add to each other and provide more total RF signal.
- 3) When both antennas have a strong signal, but they are out of phase with each other, phase cancellation between them will reduce the signal level reaching the receiver. When this occurs, the receiver reverses the phase of one of the antennas, thus restoring the RF signal in most cases.

The problem with this approach is:

- 1) The receiver doesn’t react until it is already in trouble.
- 2) There is always the possibility that switching phase will make a marginal problem worse.
- 3) Since the switching circuitry is in the RF signal path and is triggered only at low RF levels, it can produce a “click” when the switching occurs.

A special adaptation of this diversity technique is a microprocessor controlled algorithm called SmartDiversity™ offered by Lectrosonics in compact receivers. Embedded firmware in the receiver controls the diversity sensing and switching circuitry based upon an analysis of RF level and the rate of change of RF level. The firmware determines the optimum timing for switching and sampling to minimize dropouts and eliminate noise in the audio that could be caused by the switching activity. This “intelligent” algorithm also integrates with the SmartSquelch™ firmware in these receivers to employ “opportunistic” sampling and switching. The system will take advantage of brief squelching activity to switch, then sample and determine the best antenna phase setting while the audio is being muted by the squelching system.

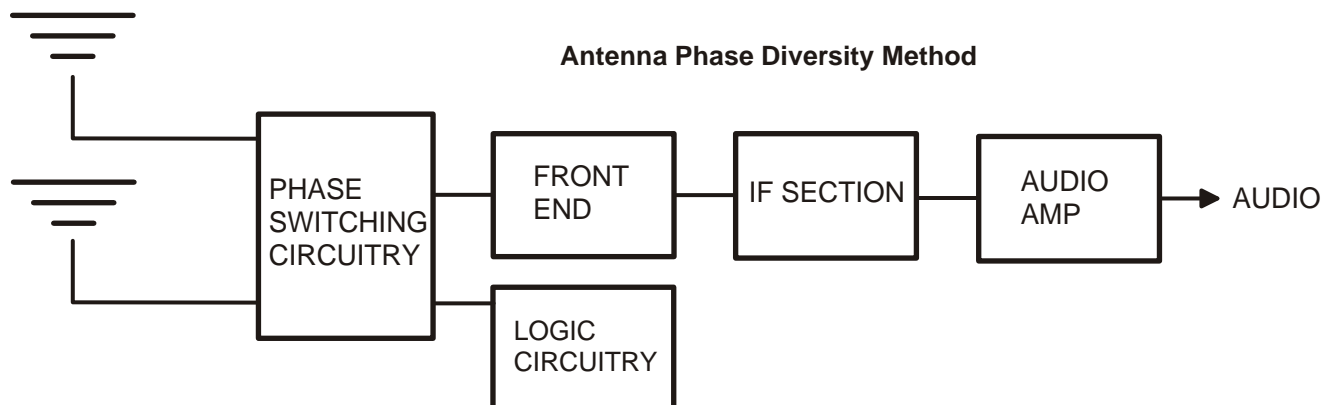

AUDIO SWITCHING DIVERSITY

This approach uses two separate receivers, selecting the audio output of one of the receivers. It is quite effective at overcoming dropouts, but only provides a minor improvement in operating range. The switching action is usually triggered by comparing incoming RF levels and switching to the receiver with the stronger RF signal, which usually produces a better signal to noise ratio in multi-path conditions.

This method is often called “true diversity” by some manufacturers, seemingly to discredit other diversity techniques and place a particular receiver model in a more competitive position in the market. This technique is a valid approach to implementing a diversity receiver, but suffers from some inherent limitations just like other diversity techniques.

First of all, the physical size of two receivers is greater than a single receiver (common sense). Given that the physical dimensions of the front-end filters and circuitry in a high quality receiver are limited to a certain minimum size due to the frequency wavelength, this design is impractical for compact receivers intended for field production. In addition, two receivers require more power than one, which imposes another limitation to using this approach to diversity reception on a compact, battery powered receiver. In order to implement this technique in a compact, battery powered receiver, serious compromises must be made in the circuit design to reduce the physical size and power requirements.

This diversity reception technique is, however, very effective at minimizing dropouts in a receiver design that is not limited by power requirements, physical size and cost. The logic behind this approach assumes that if the signal at one antenna is bad, then the signal at the other antenna is good. More often than not, this is the case, but there are still circumstances that occur where a poor signal exists at both antennas.

The switch from one receiver audio output to the other must occur at the “zero crossing” point in the audio signal, or a click or pop will be heard. This means that additional circuitry is needed in the receiver to determine when the audio signal is at the zero crossing point and enable the switch at that instant. In addition, the receiver audio output levels must be perfectly matched, or an audible change in level will occur when the switching takes place.

Some receiver designs handle switching so poorly that they actually interrupt the audio signal briefly, or shift the audio level when the switch occurs. You can well imagine what that sounds like when the overall RF level is low or in severe multi-path situations and the receiver is switching back and forth rapidly.

Another problem with an audio switching design revolves around the method of sensing used to trigger switching. If the switch is activated by comparing RF signal strength in the receivers, it is likely that the switch can be “fooled” by external RF signals at one antenna. For example, if an RF noise source is near one of the antennas, the receiver might think that this antenna has a stronger RF signal level and favor it in the switching. An external RF noise source produces mostly high frequency audio noise in the receiver, so this type of design could have serious problems in a typical stage setup where synthesizers or other digital equipment in use. If the receiver offers high selectivity, then using the RF signal level at each receiver to control the switching is a safe assumption.

While most of this discussion may seem negative toward this approach to diversity reception, the fact is that this technique is one of the more effective methods of reducing dropouts when it is used in a high quality receiver design.

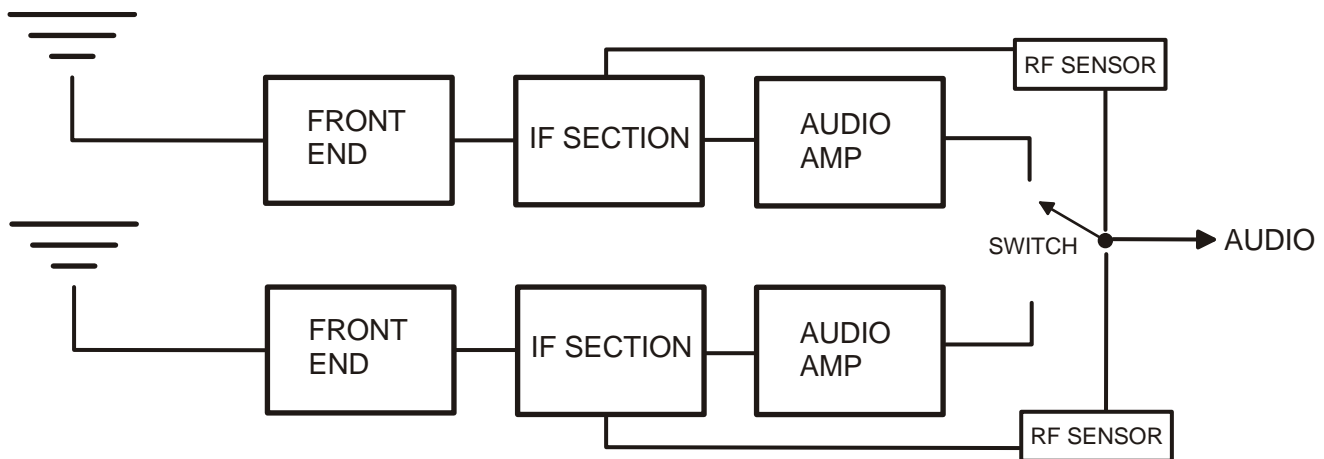

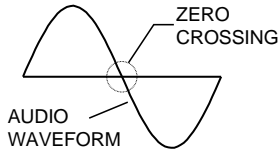

The “zero crossing point” in the audio signal occurs between the positive and negative voltage swings when the voltage is at zero.

RATIO DIVERSITY (audio ratio combining)

This approach to diversity reception utilizes two separate receivers, sharing a common oscillator and audio circuitry. The audio outputs of the receivers are used simultaneously, being mixed by a “panning” circuit in a ratio controlled by the comparative RF levels at the receivers. This method anticipates dropouts long before they occur, since the comparative RF level sampling and mixing starts taking place at higher RF signal levels than in other diversity designs. By the time the signal level at one receiver drops low enough to produce noise, the panning circuitry has long since shifted to the other receiver.

The ratio combining process is similar to an audio switching diversity design, in that both techniques assume that if the RF level at one receiver is low, it will be better at the other receiver. The difference between these two techniques rests in the fact that a ratio diversity receiver utilizes both receivers simultaneously, whereas an audio switching type uses only one receiver at a time. This difference comes into play when the overall RF signal level is low and the receiver is struggling to find enough signal to produce a usable signal to noise ratio. In this situation, two antennas will gather more signal than one, and the panning circuitry in a ratio diversity receiver will continue to balance the outputs of the two receivers for the lowest noise even at very low RF levels. A switching diversity receiver will be busy selecting one or the other receiver, but not be able to use both receivers at the same time.

Another advantage to the ratio diversity technique over other types resides in the fact that no hard audio switching is used in the process. Since no switching occurs, there is no need for additional circuitry to enable switching during zero crossing in the audio signal. Output level differences in the two receivers are also less critical since no abrupt switch occurs. Lectrosonics OptiBlend™ ratio diversity circuitry is damped to provide a smooth, seamless panning action that eliminates audible artifacts of diversity operation.

When both receivers have a strong signal, their audio outputs are mixed together evenly. As the signal level drops, the panning process will begin to occur at about 40 μV . As the RF signal continues to drop, the panning action becomes more aggressive until the signal level is at about 1 μV , when the circuitry finally acts as a soft squelch and mutes both channels. As long as either antenna has at least 2 or 3 μV of signal, the receiver will continue to deliver a usable audio signal to noise ratio.

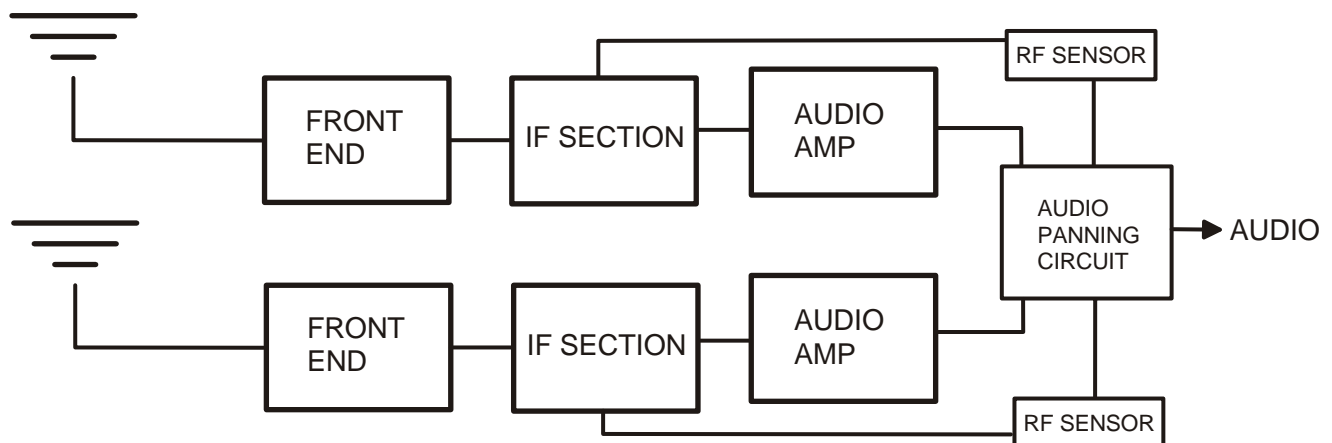

Sensitivity is another aspect of receiver performance to consider before making an assumption that a diversity design is superior by default. In the example of Comparative Squelch Thresholds shown here, the signal from the transmitter dips to a level of 5 μV due to operating range and multi-path nulls, which is not at all uncommon. A receiver that squelches at 7 μV (threshold A) in this situation will shut down and mute the audio from this transmitter signal, no matter what sort of diversity circuitry is employed. A single antenna receiver that will work to 1 μV (threshold B), however, will continue to operate and deliver usable audio.

It is always a good idea to check the sensitivity specification of any receiver being considered for purchase or rental along with the type of diversity circuitry being used in the design to get a good idea of how well the device might actually work. There are big differences from one manufacturer to another.

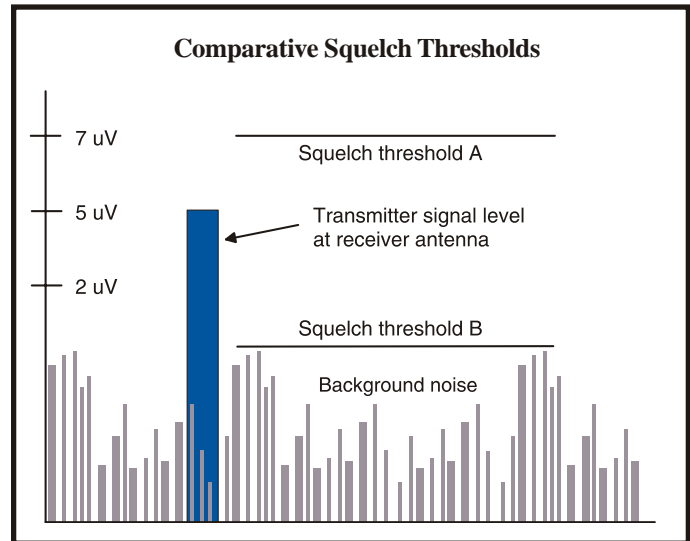

AUDIO SIGNAL PROCESSING

Audio signal processing is used in almost all sound recording and reinforcement systems to match the equalization and dynamic range of the source material to the recording media or sound system. Various methods are used for applications ranging from motion picture optical soundtrack recording and music recordings, to sound reinforcement and telephone systems. Wireless microphone systems are also subject to a maximum dynamic range to minimize noise and distortion, which requires several types of audio signal processing.

The dynamic range of an uncompressed audio signal coming from a microphone with a live talker or instrument can easily be greater than a wireless system can cleanly handle. Without compression and limiting, the background noise inherent in any wireless system will be audible. The background noise level varies radically as the transmitter is moved around. When the audio signal is present at a fairly high level, the background noise is masked out by the audio. During pauses in speech or with low level audio, however, the background noise can become clearly audible. In addition, very high input levels to the transmitter can produce distortion unless some form of clean limiting is provided in the transmitter.

The audio signal processing applied in wireless microphone systems is employed to reduce noise and lower distortion. The signal processing includes several basic processes:

- 1) Pre-emphasis/de-emphasis (utilized to increase the signal to noise ratio of the system)
- 2) Input limiting (to minimize overload distortion)
- 3) Compondors (compressor/expander noise reduction)
- 4) DNR filtering (dynamic high frequency noise reduction)

PRE-EMPHASIS/DE-EMPHASIS

Most wireless microphone systems include a high frequency boost (pre-emphasis) in the transmitter which is offset by a complementary roll off (de-emphasis) in the receiver. The process is similar to simple noise reduction systems used in some tape recorders and typically improves the signal to noise ratio of the wireless system by about 10 dB.

If excessive pre-emphasis is applied, it is possible to generate distortion (high frequency sibilants) caused by the IF filters in a narrowband receiver during full modulation. Wideband IF filters reduce or eliminate this problem at the expense of selectivity.

INPUT LIMITING

A distinction must be made between the input limiter and the compressor that is part of the overall compandor circuitry. These are two separate circuits that operate differently and are used for different purposes. The input limiter is a circuit used in the transmitter input circuitry to put a “ceiling” on the maximum signal level to keep the gain amplifier from overloading and to keep the maximum deviation within legal limits. The circuitry in the compandor’s compressor, on the other hand, is used as part of an overall noise reduction process, complemented by a mirror image expansion process in the receiver. The input limiter is at the transmitter input, followed by the compressor.

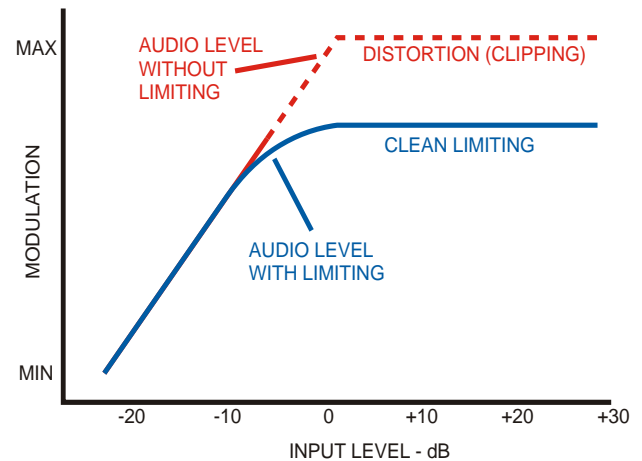

There several good reasons to use an input limiter in the audio stage of a wireless transmitter. First, government regulations restrict the maximum FM deviation that is allowed, regardless of the input signal level. Secondly, if too much signal is delivered to the audio amp in the first stage, overload distortion (clipping) will occur. It is interesting to note that only a few manufacturers include a limiter in the input stage, in spite of the fact that it is a valuable design “tool” that makes a significant improvement in the performance of the system.

A good limiter in the input stage will improve the signal to noise ratio of the system noticeably, and prevent distortion during input signal peaks. A good limiter will handle signal peaks about 12dB above full deviation. A better design will handle peaks up to 20dB. The best systems available will cleanly limit peaks over 30dB above full deviation at any gain setting.

Input overload (clipping) is used to limit the maximum deviation in most designs. While this keeps the system legal, it produces gross distortion and sacrifices the signal to noise ratio of the system. The only way to guard against overload distortion without a limiter is to lower the input gain so that signal peaks do not clip the input amp. The problem with this approach, however, is that the average signal level is then too low to produce a good signal to noise ratio in normal operation. This is one of the reasons why background noise is often audible and dropouts occur frequently in some designs.

In some circuit designs, the limiter range varies with the gain control setting so that the limiter acts directly on the input gain circuit. This restricts the limiter range to being roughly equal to the amount of gain set on the control. In other words, the limiter simply turns the gain control down during loud peaks. This approach creates a real problem with a loud vocalist, precisely when clean limiting is needed most. In this case, the input gain control will usually be set at minimum, which means that there is little or no limiting available, since there is no gain set on the input. The best limiter designs utilize a separate circuit stage independent of the input gain circuitry.

COMPANDORS

The perceived signal to noise ratio of a wireless mic system is very much improved with signal processing circuitry called a “compandor.” The term “compandor” is a combination of the words “compressor” and “expander.”

(the spelling of “compandor” with an “or” was defined by the company who manufactured some of the first IC chips for the telephone industry)

Companding is a two-fold process that depends upon a “masking” effect to improve the signal to noise ratio of the wireless system. Masking is a process of burying (or covering up) one sound with a louder one, taking advantage of the way a human ear hears things. Masking works in a wireless mic system by taking advantage of the fact that when the audio level is high enough, the ear will not hear the underlying background noise that is generated in the RF link.

The compressor action in the transmitter operates around a reference level, operating to keep high level signals lower and low level signals higher. The effect of this compression is to reduce the dynamic range of the audio signal, effectively raising the average level. Raising the average audio level farther above the background noise provides a dramatic improvement in the signal to noise ratio of the RF link in the system.

Compandors were first used in the telephone industry to provide noise reduction for long distance telephone lines where excessive noise buildup could be as loud or louder than the audio signal itself. Compandors are also used in analog tape recording processes to overcome tape hiss. An immense amount of time has been spent in engineering to improve the companding process for many applications.

Compandors for wireless mic systems use a 2:1 ratio. The compressor in the transmitter reduces the dynamic range by 2:1, then the expander in the receiver reverses the compression at a complementary 1:2 ratio to restore the original dynamics of the audio signal. In looking at the drawings below, notice that before compression, the lowest audio level is only 40 dB above the noise floor. After compression, the lowest audio signal is 60 dB above the noise floor, providing a 20dB improvement in the signal to noise ratio. The compressed audio signal is used to modulate the carrier to provide a significant improvement in the signal to noise ratio in the RF link.

There are many boastful claims made by a number of manufacturers centered around their particular companding circuitry. The compandor is critically important to the audio quality the wireless system produces, but only if the rest of the wireless system is a high quality design. It is of little importance how good the audio processing circuitry is if there are problems with the RF performance and the system is suffering from dropouts or interference. In addition, poor RF performance can produce anomalies in the RF link that generate audio signals in the receiver that did not exist in the transmitter.

Excessive high frequency noise generated in the RF link can cause the compandor to mis-track. This noise appears in the receiver along with the audio signal, but was not present in the original audio signal fed into the transmitter. Much of the noise produced by a poor RF link is supersonic, and while not audible, it can modulate the compandor, causing “pumping” and “breathing” effects in the audible sound. In the best designs, an active filter circuit in the receiver just ahead of the compandor provides sharp high frequency roll off to minimize mistracking caused by high frequency noise in the audio signal.

One of the fundamental considerations in compandor design is the effect of different attack and decay times used in the compressor and expander. The attack and decay times must be carefully controlled to optimize the dynamic action for the intended application. The compressor in the transmitter and the expander in the receiver must track in a perfectly complementary manner. A compandor idealized for high frequency program material will cause excessive distortion of low frequencies, since the gain will be affected by the voltage level changes on each cycle of the low frequency audio waveform. A compandor with slow attack and release times will reproduce low frequencies without distortion (ideal for the lower frequency fundamentals of bass guitar, for example) but it would then not be fast enough to accurately track the fast rise times of higher frequencies. So, what occurs is perhaps a compromise in the design process.

FIRST HALF OF COMPANDING PROCESS
(2:1 COMPRESSOR IN TRANSMITTER)

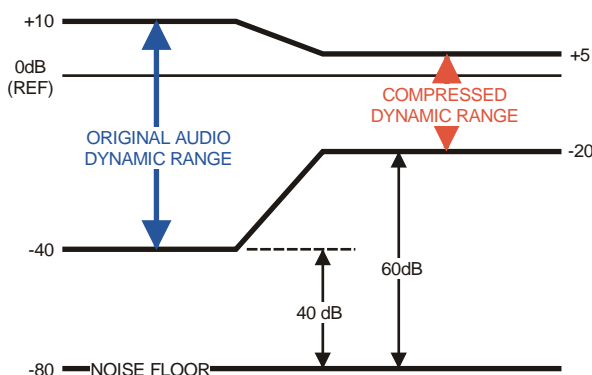

SECOND HALF OF COMPANDING PROCESS
(2:1 EXPANDER IN RECEIVER)

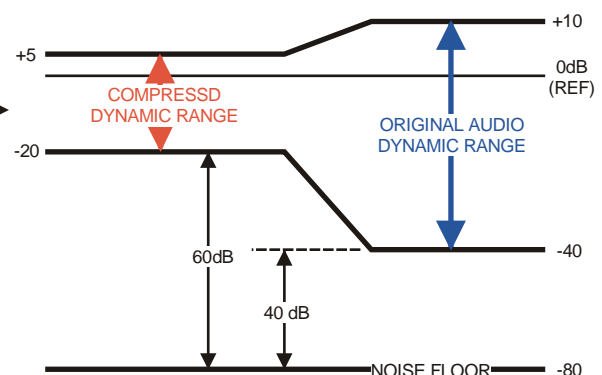

NOTE: The specific values shown in this drawing are only used to depict the concept of a compandor. These values will vary significantly in various designs and at various transmitter input signal levels.

If the compandor has a fast attack time and a slow release time, brief transients in the audio signal will control the compandor gain for relatively long periods of time. The resulting problem is “breathing,” which is residual background hiss heard following each word or sound. The cure for this is a faster release time, however, this increases low frequency distortion because the circuitry will then act on the trailing side of a low frequency waveform, causing distortion.

A conventional compandor with a single attack time and a reasonable release time for the entire audio spectrum will still increase system distortion about 0.5% at 200 Hz and about 1% at 100Hz. There is no way around this problem in a conventional compandor.

The problems with high and low frequency distortion have given rise to a new generation of compandors, where high frequency components of the audio signal are processed separately from low frequency components. This process, called “dual-band companding,” is only found in the most advanced wireless mic systems, since it adds considerably to the cost of engineering and manufacturing the system.

The dual-band companding process utilizes crossover network, somewhat like a speaker system. The audio signal is separated into high and low frequency bands, and then each band is processed with its own idealized attack and decay times. The high frequency section utilizes faster attack and decay times appropriate for the typical signals it handles, and the low frequency section operates with longer time constants for the typical signals it handles. There is also interaction between the two compandors to insure linearity in the audio signal.

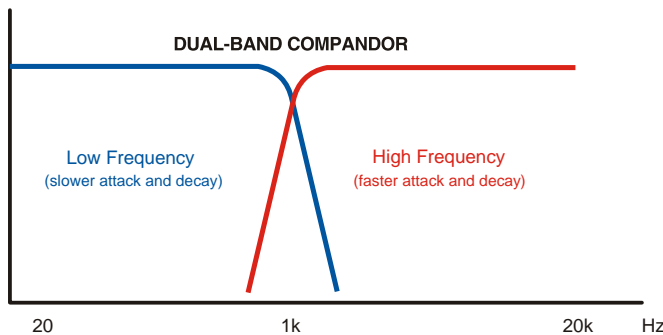

Note that the compandor acts only on the dynamics of the audio signal, without affecting the frequency response of the overall system. The plot shown above only depicts the separation in control signals that affect the compandor action. In the dip shown at 1 kHz, both high and low frequency sections of the compandor circuit control the dynamic action equally.

DNR FILTERING

As a finishing touch to a complete audio signal processing package, DNR filtering (dynamic noise reduction) is added to provide an optimum signal to noise ratio during poor signal conditions.

A dual-band compandor provides excellent, low distortion noise reduction, but an anomaly can still occur under special conditions. When the only audio signal present consists of a low level, low frequency transient, an effect called “breathing” can still occur. This happens when high frequency noise in the environment or the RF link can be heard briefly following a low frequency audio transient. In this situation, the bass compandor applies a longer time constant, allowing a brief “noise tail” to occur following the audio. This effect is most noticeable when the audio signal is at a low level, at a low frequency and the listening environment is very quiet (ie. with headphones used in a studio setting). All compandor designs exhibit this breathing effect to one degree or another under these conditions. This is not a unique problem with a dual-band compandor.

To suppress noise in this situation, a unique dynamic filter circuit is employed. DNR consists of a dynamic low-pass filter with a variable hinge point that automatically reduces high frequency noise during poor signal conditions. The hinge point frequency of the filter is controlled continuously by an analysis and combination of the RF level, the audio level and the high frequency content of the audio signal.

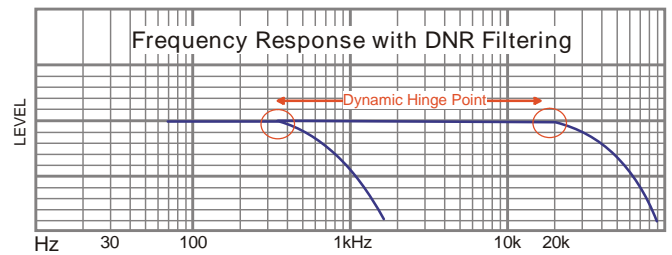

When weak RF signals and low level audio are present, the hinge point of the filter moves to a lower frequency to roll off high frequency noise. This is a single-ended process that occurs entirely inside the receiver.

DNR utilizes the masking effect somewhat like a compandor. When audio is present, even at a moderate level, or audio with high frequency content is present, the background noise will be masked, so the filter moves completely out of the way to avoid altering the original audio signal. The DNR circuit is extremely sensitive and responsive, and does not alter the natural frequency response of the overall wireless mic system.

TESTING FOR AUDIO PERFORMANCE

Some excellent tests of audio performance are outlined in a chapter in this Wireless Guide entitled “Evaluating Wireless Microphone Systems.” The tests described in this section challenge even a high performance wireless mic design, and provide dramatic demonstrations of the design challenges and performance issues described in this chapter.

ANTENNAS

The frequency of the carrier determines the “wavelength” of the radio signal. Radio signals and light travel at the same speed. If you take the distance that a radio signal travels in one second, and divide it by the carrier frequency, you will derive the actual length of one cycle of the carrier frequency. Most wireless mic transmitters and receivers use “quarter wave” antennas. This means that the ideal length of the transmitter and receiver antennas would be 1/4 of the total wavelength.

Transmitters are normally held in the hand or worn on the body so there is always an effect on the antenna caused by the user’s body. Transmitter antenna designs vary widely on units offered by various manufacturers.

Receivers are often mounted on other equipment or near large metallic surfaces, any of which can affect the efficiency of the antenna. A whip antenna, usually a quarter wave, mounted directly on a receiver chassis uses the receiver housing to provide a ground plane for the antenna. Remote antennas of various types are generally used in critical applications, or for maximum operating range.

Rather than go into the intricacies of antenna theory and design, the following information simply highlights the major concerns and operational benefits of the most commonly chosen designs.

BELT PACK TRANSMITTER ANTENNAS

VHF belt-pack antennas normally use the shield of the microphone cable as the antenna, although some older designs still exist with a “dangling wire.” UHF belt-pack designs normally utilize a separate 1/4 wavelength whip to maximize the radiated output. It is important to keep in mind that the radiated output of the antenna will be reduced when it is placed on the user’s body, leaving less radiated signal to reach the receiver. Generally speaking, it is a good idea to position the transmitter with the antenna oriented vertically, to produce a circular radiation pattern. In a vertical orientation, the user can move about at will, but still radiate a strong enough signal to reach the matching receiver.

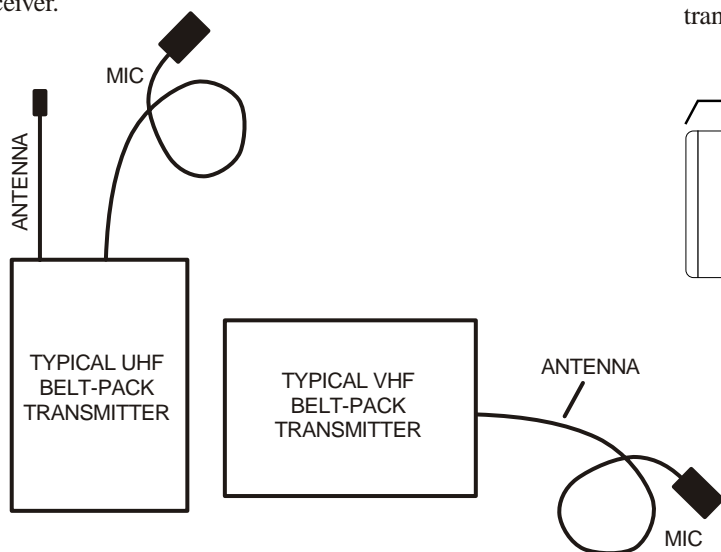

HAND-HELD TRANSMITTER ANTENNAS

Most hand-held transmitters utilize an internal antenna which radiates the RF signal through a plastic housing. A few hand-held transmitter designs use a metal housing, which becomes part of the antenna circuit. It is also common to employ flexible whip antenna protruding from the bottom of the housing, since the whip is only a few inches long at UHF frequencies.

Hand-held transmitters benefit from the fact that they are held out in the air with only the user’s hand in direct contact, allowing the antenna to radiate efficiently. In designs that use an external whip, the user’s hand becomes part of a quasi-ground plane.

A dual tapered, “hour glass” shape works very well for a hand-held transmitter. It provides a secure grip and is comfortable to hold in the hand. When held with one hand, the antenna is generally clear to radiate the signal efficiently, whether the hand is positioned on the top or bottom of the transmitter. Held with two hands, however, with one at the top and one at the bottom of the transmitter, the antenna output can suffer.

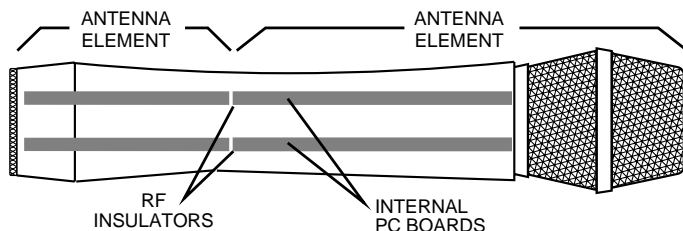

“PLUG-ON” TRANSMITTER ANTENNAS

“Plug-on” transmitters with integral antennas utilize the housing around the battery compartment as one antenna element, with the microphone body and user’s hand forming the other half of a dipole configuration. An insulator just below the input coupler separates the antenna elements. The radiated RF power from this configuration is as high or higher than standard hand-held transmitter configurations.

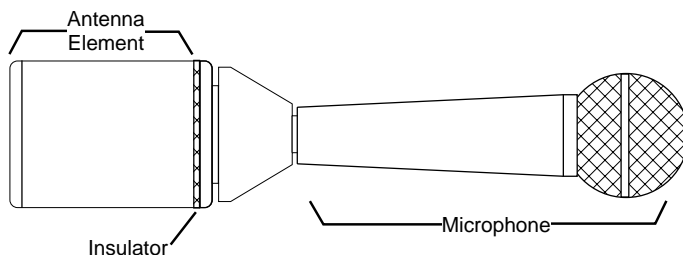

RECEIVER ANTENNAS

There is little that a user can do to significantly alter the efficiency or design of a transmitter antenna. With respect to receivers, however, there are a number of alternatives to the antenna supplied with the receiver. A wide variety of different types of antennas are available from a variety of sources, including specialty manufacturers who make only antennas. The purpose of this text is only to highlight a few general classes of antennas that serve some usefulness in operating wireless microphone systems. Rather than attempt to discuss the complex topic of antenna theory, simplified descriptions of some basic types are offered, including a few suggestions of which types might serve certain applications.

In some applications, the performance of the antenna may be less important than the physical limitations of the installation. For example, in a boardroom it is usually important that the components in the sound system be virtually invisible. Placing a high performance antenna on one of the walls of the boardroom is simply not permissible. The efficiency of the antenna is usually not a problem, since the distance from transmitter to receiver antenna is normally quite short. So, an antenna that blends into the decor, or is invisible, makes sense for this application, at the expense of using less than an ideal type.

In other applications, such as theatre and stage, the performance of the antenna is the primary concern, while the physical appearance of the antenna is of little or no importance. In this example, the antennas may have to be located several hundred feet from the stage. In addition, a fair amount of RF noise or interfering signals can be present at the antenna location. So, what makes sense in this application is to utilize a high efficiency, directional antenna, regardless of its appearance. The antenna is out of sight of the audience, so it makes little difference what it looks like. The directional nature of the antenna can provide a strong RF signal from the stage, and also provide rejection of interfering signals coming from other directions.

1/4 wave whip

This is the antenna that is normally supplied with a wireless mic receiver. The whip can be a fixed length, or it can be a telescoping design. The length is approximately 1/4 wavelength of the operating frequency of the system. The whip functions as part of a “quasi-ground plane” arrangement, with the whip working as the radiating element, and the receiver housing working as the ground plane. For most applications, a 1/4 wave whip mounted directly on the receiver provides adequate operating range. Oriented vertically, it provides a circular shaped pattern with equal sensitivity in all directions except straight up and down.

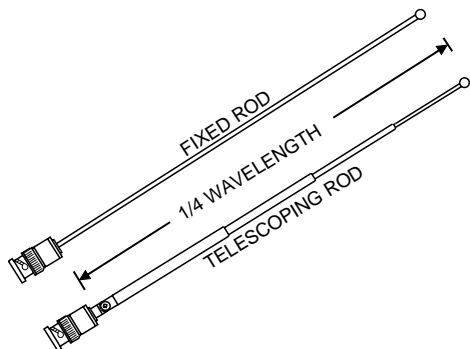

Whip antennas can produce problems in multi-channel wireless systems when the receivers are close together. In most applications, however, a whip antenna is generally sufficient when operating up to three or so wireless systems in the same room. It is best to use an RF multi-coupler and external antenna/s for any multi-channel system consisting of more than three channels in the same location.

Helical style (rubber duckie)

Similar to a conventional whip antenna, this type offers a shorter physical length, but exhibits a more limited bandwidth than a 1/4 wave whip. Instead of extending the element out a 1/4 wavelength in a straight line from the connector, a helical whip is wound into a coil. The wire in the element is the same electrical length as a straight whip, but the overall physical length is shorter and more flexible after being coiled. A helical antenna is usually not as efficient as a straight 1/4 wavelength whip, but in some applications the durability of a helical design is more important than the efficiency.

The most common application for helical antennas is with camera mounted receivers used for field video and film production, where a longer antenna could easily be broken or might get in the way of other equipment.

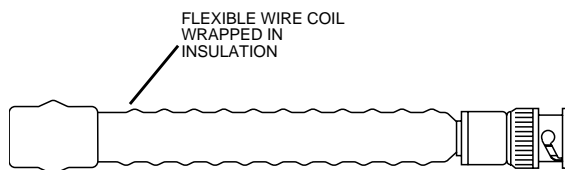

Ground Plane

This type of antenna provides significant gain over a 1/4 wave whip. It is constructed of a single, 1/4 wavelength vertical element surrounded by radial elements around its base. The best impedance match is provided when the radials are angled downward from the vertical at a 45 degree angle. The antenna should be positioned so that the radials are closest to the nearest boundary (floor or ceiling). Used outdoors, it should normally be mounted vertically (the single element pointed upward). If it is mounted on the ceiling of a room, it will generally work best inverted, with the single element pointed downward, so that the radials are closest to the ceiling.

A ground plane antenna exhibits a circular coverage pattern, perpendicular to the vertical element. This would be a good choice for applications such as in a centrally located position in a concert hall or large room away from significant sources of RFI.

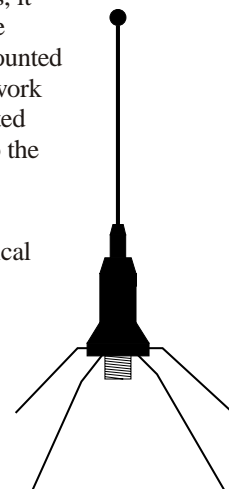

Coaxial

This is a special type of antenna that can be made from common coaxial cable. It functions much like a dipole antenna. The center conductor is cut to 1/4 wavelength and protrudes beyond the shield of the coax. The shield is also cut to a 1/4 wavelength and is folded back over the coaxial cable for a better impedance match to the receiver.

A coaxial antenna can be positioned vertically or horizontally. While this type of antenna is not particularly efficient, it does permit mounting in awkward installations, such as above a suspended ceiling or concealed along a wall. When positioned vertically, it provides a circular coverage pattern for transmitters located perpendicular to the axis of the antenna.

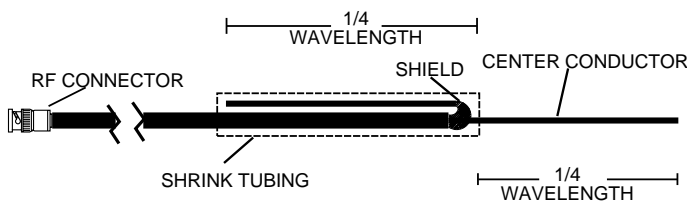

Dipole

This is a dual element antenna that exhibits a circular pattern. Each element is normally cut to 1/4 of the wavelength. The maximum sensitivity is achieved with the transmitter located perpendicular to the elements. Since a dipole antenna is easy to construct, it is used in many applications ranging from a concert hall to an outdoor production scenario.

Shown here is a versatile dipole design with tunable elements. A scale along the body of the antenna is marked for frequencies from 500 to 800 MHz. The elements are folded along the body for frequency adjustment, and to make the unit more compact for storage.

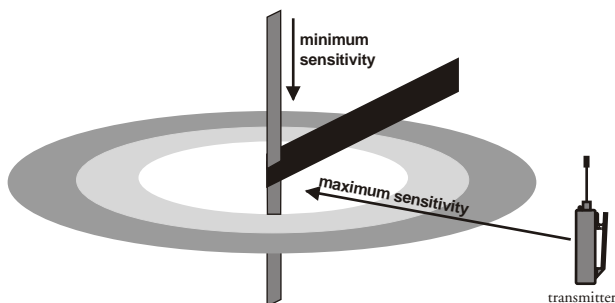
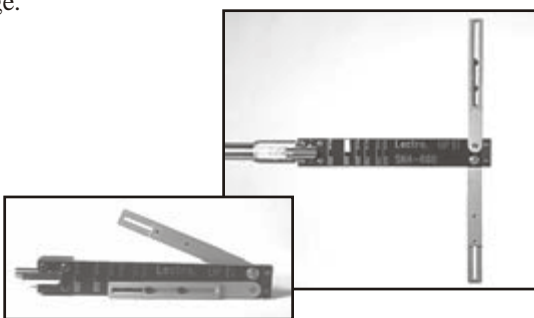

LPDA

This abbreviation stands for “Log Periodic Dipole Array.” This is a multi-element, directional antenna that operates over a wide frequency range (such as 500 to 800 MHz) with a typical gain of 4 dB over a dipole antenna. The pickup pattern is similar to a cardioid microphone, perpendicular to the radial elements.

A log periodic antenna is commonly used as a single antenna feeding a multi-channel wireless system which is operating on a variety of frequencies. An LPDA antenna should be mounted so that it is not close to a nearby reflecting surface. At UHF frequencies there is usually not a problem with placement, but at VHF frequencies there can be some limitations in indoor use.

LPDA antennas

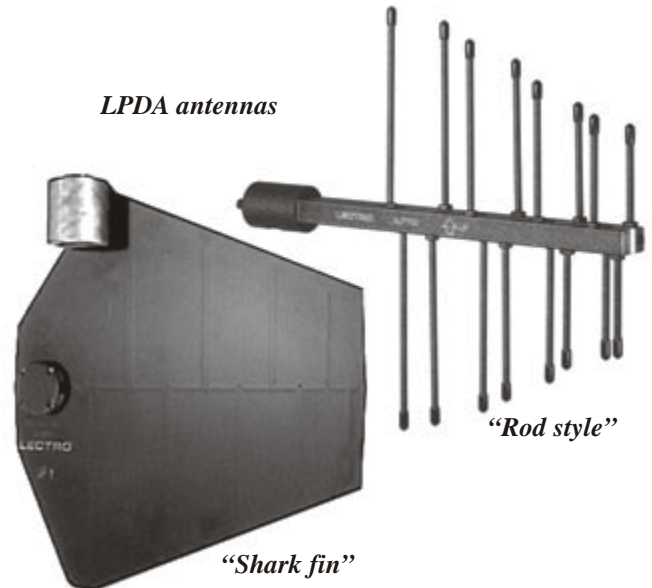

Yagi

This is a multi-element, directional antenna that operates over a limited frequency range. A Yagi antenna is a “parasitic array” of dipole elements. It consists of a basic dipole element modified by other dipole elements (the parasitic elements) which are placed at specific distances in front of and behind the dipole element. The element behind the dipole is called the “reflector” and the elements in front of the dipole are called “directors”. As more “director” elements are added in front of the dipole, the pattern becomes more directional. A typical 3-element Yagi will produce about 3 or 4 dB of gain over a dipole. A 5-pole design can produce as much as 10 or more dB of gain over a dipole. The higher the gain, the more critical the placement.



FREQUENCY SYNTHESIS

Synthesized wireless microphone systems have become increasingly popular in recent years. Except for some very inexpensive systems intended for the consumer market, a clear majority of all new systems now being introduced are synthesized. Wireless users are attracted to the idea that they are getting more for their money and feel empowered by the ability to rapidly change to a new operating frequency. Dealers like the fact that they can sell the equipment they have in stock; it is not necessary to wait for special order systems on custom frequencies. Synthesized wireless microphones are also popular with field news crews, location film and TV production companies, touring groups and other wireless users who frequently travel. The term “frequency agility” (referring to synthesized equipment) has become one of the common buzzwords in the professional audio industry.

Despite their undeniable attraction, synthesized wireless microphone systems have some significant limitations and shortcomings, and sometimes introduce new problems while solving old ones. For example, synthesizers often affect audio quality quite significantly, yet the connection between audio performance and synthesis is not apparent to most wireless users. Synthesis also affects many other areas of wireless mic performance, as well as battery life, size, weight and cost. Because synthesis is a mixed blessing, a basic understanding of the technology will be very helpful in making informed choices when selecting and using wireless mics.

FREQUENCY SYNTHESIZERS

All synthesized wireless microphone equipment use a phase locked loop circuit of some type to control the operating frequency. In this type of synthesizer, the output frequency is generated by a voltage controlled RF oscillator, usually operating directly at the desired output frequency. The voltage controlled oscillators in wireless transmitters often also have a second control input used to FM modulate the output signal. Some more complex synthesizers, however, use a separate FM modulator circuit.

The output frequency of the voltage controlled oscillator is controlled by locking it to a very stable reference crystal oscillator. This is accomplished by digital frequency divider circuits, a phase/frequency comparator, control signal filter and control signal amplifier. The stable reference frequency is divided down to a frequency equal to the desired synthesizer channel spacing. That is, if the channels are to be spaced at 125 kHz intervals, the output of the reference frequency divider will also be 125 kHz. A high reference frequency and a divider are used because 125 kHz crystals are not stable enough or too large for use in wireless mic equipment.

The output of the voltage controlled oscillator is also divided down to 125 kHz by a programmable frequency divider. For example, if an output frequency of 702.625 MHz is desired, the counter will divide by 5621 (702.625 divided by 5621 is 0.125). The outputs of the reference divider and the programmable divider are then both applied to the phase/frequency comparator. Initially, the voltage controlled RF oscillator will not be at exactly 702.625 MHz. The phase/frequency comparator will output a control signal that will drive the voltage controlled oscillator up or down in frequency as necessary to bring it to

702.625 MHz. This control signal is filtered to remove digital noise, amplified and then applied to the voltage controlled oscillator.

As the voltage controlled oscillator frequency closely approaches 702.625 MHz, the phase/frequency comparator output will change to a phase control signal. After some period of settling time, the two 125 kHz signals into the phase/frequency comparator will be locked in both frequency and phase. When this occurs, the voltage controlled oscillator output frequency will be an exact multiple of 125 kHz, and as accurate in frequency as the reference oscillator itself.

Changing the programmable frequency divider’s divide ratio will move the synthesizer output frequency in steps of 125 kHz. For example, if the programmable frequency divider is changed to divide by 5622 instead of 5621, the voltage controlled oscillator frequency changes to 5622 times 125 kHz, or 702.750 MHz. A divider ratio of 5623 yields 702.875 MHz, 5624 yields 703.000 MHz, and so forth. In theory, the output frequency range of the synthesizer is limited only by the range of the voltage controlled oscillator and the available divide ratios of the programmable divider. As a practical matter, synthesizer noise performance and other considerations normally limit the useful range to two or so TV channels at VHF and roughly four to eight TV channels at UHF.

The phase/frequency comparator also has a lock detector output that signals when the synthesizer has achieved stable on-frequency operation. In transmitters, the lock detector signal is used to turn on the transmitter output control switch, allowing the unit to begin transmitting RF. Until the synthesizer is locked, the output frequency might be anywhere within the transmitter’s tuning range and rapidly changing in frequency. Transmitting before the synthesizer is locked on frequency can cause severe interference to other equipment.

Basic phase locked loop synthesizers at lower RF frequencies are relatively simple to design using standard integrated circuits, at least if modest performance is acceptable. The high performance designs needed for professional wireless microphone systems are considerably more challenging, especially so at UHF. Careful tradeoffs must be made between noise, audio frequency response, low frequency distortion, lock-up time, power consumption, tuning range, spurious outputs, frequency step size and several other inter-related performance factors. Users of synthesized wireless systems should look beyond the appeal of synthesis to make certain that overall performance meets their needs.

SYNTHESIZER PERFORMANCE ISSUES

Synthesizers have a major impact on audio signal-to-noise ratio (SNR). Because some type of audio processing (companding) is used in the vast majority of wireless mic systems, the effects of this are not always immediately obvious. In addition, specifications based upon static measurements do not ordinarily reveal the problem. Unfortunately, some wireless manufacturers rely on audio processing to conceal the effects of various design compromises, including those in the synthesizer. A poor system SNR will be clearly revealed, however, by annoying “fizzing”

sounds or “noise tails” at the end of words. This effect is also sometimes called “breathing”. The problem is especially pronounced with certain kinds of background sounds are present, such as waves breaking, train and subway rumbles, elevator noise and heavy breathing by the performer.

Although synthesizer noise is not the only cause of this problem, it is one of the most common. The culprit is phase noise, sometimes also referred to as phase or frequency jitter. Both transmitter and receiver synthesizers are subject to the problem, and the phase noise of each is additive. The receiver FM demodulator cannot distinguish the synthesizer phase noise from the desired audio modulation, resulting in low level noise being introduced into the audio. This artificial noise “floor” causes the “noise tails” at the end of words, as well as audible level discrepancies.

For a number of reasons, synthesizers have far more phase noise than crystal-controlled oscillators. The phase noise also rises with increasing frequency, making UHF systems more susceptible than VHF systems. To partially offset this, UHF systems normally have wider deviation (increased modulation) compared to VHF systems. The design of very low phase noise synthesizers at UHF frequencies is quite challenging, and good designs tend to be more complex and expensive than those with lower performance. Phase noise also affects channel spacing; high performance circuits with 25 kHz channel spacing are usually considerably more difficult to implement and more expensive than those with 100 kHz or more spacing.

Synthesized equipment is typically more susceptible to mechanical shock and vibration than are crystal controlled designs. Unless specific preventative measures have been taken, handling or bumping a synthesized transmitter or receiver is more likely to cause audible “thumps” in the system output. Even then, the transmitter and receiver enclosures need to be more rigid and designed so as to minimize coupling of the shock and vibration to the synthesizer circuitry. Electrical transients also cause serious problems; battery powered units must be designed to prevent noise on the dc lines due to loose battery contacts. Receivers operating from ac lines must have sufficient filtering and regulation to prevent power line transients and noise from reaching the synthesizer circuits.

Power consumption for synthesizers is always considerably higher than for crystal-controlled circuits. Although great strides have been made in low-power high-speed digital circuitry, synthesizer current drain is still considerably higher than desirable. This is especially true of UHF equipment, which requires very high speed frequency divider circuitry. It is not unusual for the synthesizer in a high performance UHF transmitter to represent 35 to 50% of the total current drain of the unit. The digital circuitry also requires regulated operating voltage, often at the expense of efficiency and a further reduction in battery life.

Synthesized transmitters will have spurious outputs, as do crystal controlled transmitters. However, except for harmonics of the transmitter output frequency, spurious outputs will be quite different for the two types of units. Crystal-controlled transmitters typically have numerous low-level output spurs, usually separated from the carrier by 10 MHz or more. Synthesized transmitters almost always have low level spurious outputs

relatively close to the transmitter frequency. In most cases, there will be spurious outputs above and below the carrier by an amount equal to the channel spacing.

That is, if the transmitter output frequencies are spaced at 100 kHz intervals, spurious signals 100 kHz above and below the carrier will be present. This is often surprising to those accustomed to crystal-controlled transmitters, where close-in spurious signals are frequently an indication of problems. Synthesized transmitters sometimes also have spurious outputs above and below the carrier at the synthesizer reference oscillator frequency, typically 3 to 10 MHz. Both types of transmitters will also have at least small spurious outputs at the harmonic frequencies. Well-designed synthesized transmitters generally have fewer spurious outputs than a crystal-controlled transmitter and the level of spurious signals will usually be lower.

Synthesizer turn-on and turn-off can create severe problems when several systems are in use. Almost all synthesizers sweep across a wide range of frequencies upon initial turn-on. Some amount of time is required for the digital circuitry to “lock” the output frequency to the correct value. If the transmitter synthesizer sweeps across another active wireless channel when turned on, the second system will experience severe interference. A maximum audio level “thump” is the most common result.

Synthesized transmitters are required to disable the RF output until the synthesizer is properly locked. However, some units have been found that do not have the disable circuitry, or do not reduce the output sufficiently to prevent interference. Unfortunately, it is quite possible for a transmitter to meet the minimum FCC isolation requirements and still be capable of causing this problem, especially when it is close to a receiver. Some designs also create momentary interference when turned off, with RF output continuing for a short time after the digital circuitry has lost frequency control. This problem is serious, so it is essential to verify that synthesized wireless transmitters turn on and off cleanly before using them for a professional application.

RECEIVER PERFORMANCE

Another important consideration in wireless microphone systems is receiver selectivity and interference rejection. A synthesizer can easily tune a receiver’s center frequency over a wide range. For the receiver to work properly, the RF filters at the input of the receiver must somehow cover the entire synthesizer tuning range. The most common approach is to simply to make the receiver’s RF filters very wide, accommodating the required range. This almost invariably compromises the receiver’s selectivity and its ability to reject unwanted RF signals that can cause interference. The wider the tuning range, the more serious the performance compromise.

The preferred approach is to equip the receiver with electronically tunable RF filters, especially if a relatively wide tuning range is desired. While this can work quite well, it does have a number of drawbacks, cost being high on the list. The extra component costs are significant and the initial alignment can be time consuming. Filter tuning versus the control signal is virtually always nonlinear, necessitating circuitry to store the required control signal magnitude for each frequency and generate the correct value signal.

One common type of electronically tunable RF filter uses varactor (voltage variable capacitance) diodes as the tuning element. Unless very well implemented, this type of filter can compromise performance in several ways. One problem is that some varactor diodes, especially inexpensive ones, have internal losses that can limit filter selectivity. This is a particular problem at UHF, where small component losses can greatly affect filter performance. The result can be that there is no actual advantage over wideband non-tuned designs.

Varactor-tuned RF filters can also be overloaded by strong RF signals, a very common situation with wireless microphone systems. This occurs when the voltage generated inside the filter by strong RF signals overwhelms the applied tuning voltage. When this happens, the filter tuning changes and its selectivity is degraded. Sometimes, the filter tunes away from the desired signal and towards interference, seriously compromising system performance. Filters using other types of tuning components, such as PIN (switch) diodes can perform much better in this situation.

It is possible to improve the performance of receivers with wideband filters by using special overload-resistant RF amplifiers. Because of the high power consumption of these amplifiers, the approach is only feasible with larger ac-powered receivers. Even with sophisticated circuitry, however, performance of wideband and tunable-filter receivers will still not match that of a quality fixed-frequency design. For this reason, only high quality, professional synthesized equipment should be used for demanding applications.

OPERATOR INTERFACES

Typically, the programming interface to frequency synthesizers is in the form of a long binary word, or even two shorter binary words. This must be translated to a form that is meaningful to the user. Several approaches have been used; some simple and some relatively complex. On the complex end of the scale, some synthesized wireless transmitters and receivers use an on-board microprocessor to drive a LCD display. Operating frequency can be displayed directly in six-digit form, such as "702.625". Frequency can be changed via "up" and "down" pushbuttons, on a small control panel, or perhaps inside a cover or in the battery compartment. Generally, some form of electronic lock or cover is necessary to prevent accidental frequency changes.

Some equipment uses a "channel and group" approach. In this case, based upon some rationale, the manufacturer designates specific frequencies as being a certain channel within a designated group. The number of available groups, as well as the number of channels within the groups, varies from manufacturer to manufacturer. In particular, the actual frequencies represented by channel/group numbers is almost always completely different from manufacturer to manufacturer. This tends to make the approach very unwieldy if equipment from more than one manufacturer is in use at a location, and a serious problem if a chart of actual frequencies versus channel/group numbers is not available.

Some equipment offers the choice of direct frequency display or channel/group display. In either case, it is usually necessary to step thru all the intermediate choices to get to a desired new choice. Not only can this be time consuming, it can be a serious problem if frequency changes are required while other wireless

systems are in use. That is, if a transmitter should momentarily output a signal at each of the intermediate steps, the potential for interference is very high. There can even be problems with receivers, as a brief period of unwanted audio can occur during tuning. Unless all frequencies will remain unchanged during a performance, it is essential that the transmitter have provisions to inhibit output until the final frequency is reached. There is particular risk for ENG use, as several types of equipment might be in use, there is no overall control and setup time is short to non-existent.

LCD displays on transmitters offer an intuitive appeal with a direct frequency, group, etc. readout, but considering that transmitters are the most "handled" part of a wireless system, they can also introduce a problem with fragility. Simple screw-driver-adjust subminiature rotary switches offer ruggedness, low cost and reasonable ease-of use. In addition, unlike units with LCD displays, the switches can be adjusted with the transmitter turned "off", eliminating any potential interference problems that could occur while changing frequencies. Switches also provide rapid access to widely spaced frequencies, as it is not necessary to step or scroll sequentially thru all intermediate selections, as is true of pushbutton type controls.

Displays for receivers are considerably more useful, especially those used for studio or fixed installation applications. In such use, it is not uncommon to use more than one transmitter with a particular receiver. The display lets the audio team keep track of which transmitter will be received. In addition, the risk of interference to other systems is minimal and the operator can mute any unwanted audio. The display is also useful for other purposes such as transmitter low battery warnings and other miscellaneous system information. Finally, a front panel receiver display is particularly useful if the receiver is being remotely controlled.

OPERATIONAL ISSUES

One of the primary attractions of synthesized wireless microphone systems is the ability of the user to quickly change frequencies. In many applications, this is also one of the primary disadvantages. In fact, several organizations with large numbers of wireless systems will not use synthesized equipment unless it can be "locked" to prevent field changes or restricted to a small pre-established set of "allowed" frequencies. The problem is that maximizing the number of available wireless frequencies requires careful frequency coordination and firm control of frequency utilization. Just one or two synthesized systems and an undisciplined operator can easily cause very serious interference problems in such an environment, often with costly consequences.

On a smaller scale, any organization using more than two or three wireless systems can run into a small-scale version of this problem. This is especially true in major metropolitan areas and when the wireless is not under the control of a single person or a small team. In such situations, the ability to change frequencies is the ability to interfere with another system. In particular, the frequency relationships that cause intermodulation are not at all obvious, so random frequency changes always have the potential to create serious problems for another system.

Synthesized systems can also be a problem for ENG and similar applications. There is no central control of frequency assignments and pressure situations are routine. When several ENG crews are present, a late arrival or a simple frequency change to improve reception can create serious problems. Suppose wireless user "A", hoping for a little more range, changes frequency, thereby creating an intermod problem for user "B". "B" then changes frequency to avoid the intermod, causing interference problems for users "C" and "D", in turn causing both to change frequency themselves. Now "C" causes new problems for "A" and "D" creates a problem for "B". This kicks off another round of frequency changes, possibly all while an important event is occurring and no one is getting quality wireless audio. While there might not be a really good answer to interference between users from different organizations, madly changing frequencies during the event is surely one of the worst.

Synthesized equipment is extremely valuable for EFP, touring groups, lecturers and others who frequently travel from location to location, especially when they have control over all wireless systems at the site. Synthesized equipment also works well as spare or "floating" systems, since they can be set to the same frequency as equipment removed for maintenance or being temporarily used elsewhere. With proper frequency coordination, synthesized systems are invaluable for temporarily augmenting an existing system for a special event. There are also a number of other applications where frequency agility is highly useful. However, the idea of using agility to permit just showing up and picking some "good" frequencies is often more illusion than reality.

INTERFERENCE

“Interference” is often blamed by inexperienced users as the cause of noise in a wireless system, even though there are several other common causes of poor signal to noise ratio that commonly occur. RFI (radio frequency interference) is a nebulous process at best. With respect to wireless mic systems, interference is generally defined as an undesired RF signal which causes noise or distortion. It can also cause limited operating range and drop outs. Interference can result from external RF signal sources such as television station broadcasts, or it can be generated within a wireless system itself. Interference is also generated by operating multiple systems in the same location. To further complicate matters, interference can also result from some combination of all of these sources.

Interference in a single channel wireless system normally results from an external RF signal or RF noise near the receiver. This type of RFI usually results from a signal on the carrier frequency of the system, or even on an IF frequency. In multi-channel wireless systems, radio frequency interference is a much more complex matter, since the wireless systems themselves can generate RF interference within the overall system.

Multi channel wireless systems always require higher performance components than simple one or two channel systems for the following reasons:

1. Interference from external sources is a problem for any wireless mic system, whether a single or a multi-channel configuration. In a multiple receiver system there are many more possibilities for external RFI.
2. In addition to external RFI problems there are “in system” RFI problems that are generated by the multiple receivers and transmitters themselves. These “in system” RFI problems are usually more numerous and harder to cure than the external RFI problems.
3. Furthermore, external sources can combine with the normal RF signals in the systems to create additional problems.

It is possible to avoid a number of problems by spacing the wireless frequencies very far apart; however this also restricts the number of systems that are usable in any one location. If the user wants a large number of channels in one location, then some of the channels are going to be placed relatively close together. This will very quickly “separate the sheep from the goats,” with respect to the individual wireless system design.

EXTERNAL SOURCES OF RFI

Wireless mic systems operate within specific frequency bands allocated by the FCC (Federal Communications Commission). Everybody (and their brother’s dog) wants more spectrum space to operate all kinds of RF devices at whatever power levels they might need to make their particular devices work. The applications include wireless mics, intercom, IFB, remote control, communications, video signals, digital data transmissions, and so on. The simple fact is that there is not as much spectrum space available as there are demands on using it. So, what we are left with is “shared spectrum space,” where wireless mic systems utilize the same frequency bands as other “more important” users.

Wireless mic systems generally operate in several bands from 150 MHz to 216 MHz, which includes the VHF TV channels 7 through 13, or in the 470 MHz to 806 MHz UHF band (TV channels 14 through 69). TV channels 60 to 69 (746 to 806 MHz) are being re-allocated, as of the date of this writing, for other applications. In addition, the band from 470 to about 516 MHz is also being re-allocated for public safety applications. The demand for more spectrum usage is increasing while the available spectrum for wireless microphones is decreasing.

Above the TV band is another part of the UHF spectrum from 902 to 928 MHz. This upper UHF band is a “general purpose” band being used by a multitude of different applications ranging from garage door openers and amateur radio, to home-use cordless telephones. Generally speaking, the 902 to 928 MHz band is not a good choice for wireless microphone systems, especially for professional use in traveling applications. Interference is virtually guaranteed in this band.

Since multi-channel wireless mic systems often utilize inactive TV channels, one of your first considerations in operating a multi-channel system in a particular area often involves identifying the local TV stations. If you try to operate the wireless mic system on the same frequency as the local TV transmission, there is little hope that your battery powered transmitter signal will have a chance of overcoming a local TV station signal (which may be powered by Hoover Dam). As DTV stations come on the air, and analog telecasts remain active, the available spectrum decreases dramatically.

There are also numerous business radio services that share the non-broadcast VHF spectrum fairly close in frequency to the wireless microphone allocations. RFI from these sources is usually rare, involving some sort of intermodulation problem, rather than from a direct signal on one of the wireless frequencies. Other sources of external direct signals can come from two-way radios, leaky cabling from CCTV systems, temporarily installed (rental) wireless systems, wireless intercom systems, and numerous other radio devices.

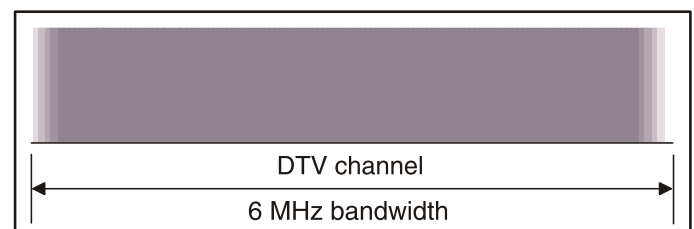
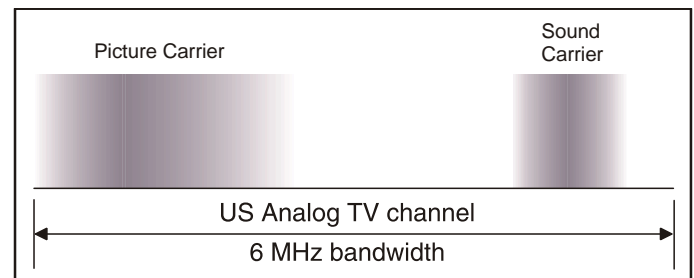

In addition to direct signals from external radio devices, there are also numerous sources of RFI possible from what is called “man made noise.” This is generally broad band RF noise generated by a number of different types of devices including switching power supplies, computers, computer peripherals, computerized telephone systems, digital signal processing equipment and a broad assortment of electrical power equipment. Locating the sources of RFI from these types of sources is usually a matter of turning off other devices one at a time and locating the culprit through a process of elimination.

Doing a “sound check” for the wireless system is just as necessary as checking out a sound system itself. TV stations normally operate with continuous carriers 24 hours a day, so if RFI is going to be a problem generated by the local TV transmissions, it will usually be constant. Business radio services, however, usually operate within normal business hours of 8PM to 5PM, so evening hours are generally free of business radio interference. Other radio signals (and there are lots of them) in the area may operate at any time, so you simply cannot predict when they might generate an interfering RF signal.

The best approach is to select clear TV channels, complete a frequency coordination plan for the systems and use only very high selectivity receivers that also provide high IM and image rejection. If you do not understand how to rate the selectivity or IM rejection capability of a particular receiver, call the manufacturer. If they can’t give you a clear explanation, you should look elsewhere, because this is one of the most fundamental aspects of any wireless mic receiver. Marketing “hype” in advertising is one thing, but reliable RF performance is another.

INTERMODULATION

All active devices, such as transistors, are non-linear. When two or more signals are present at any level in a non-linear electronic device, a phenomenon called “intermodulation” occurs. In an audio amplifier this would be called “intermodulation distortion,” or “IM distortion.” For example, if two signals are present at the same point in a circuit component, a sum and a difference signal will be produced. This is called 2nd order IM, since there are

2nd ORDER INTERMODULATION



two frequencies involved, and first harmonic of each frequency is the frequency itself.

In this example of 2nd order IM the frequencies (89 and 96 MHz) fall within the commercial FM radio band. Even though the commercial FM radio band is generally very full, and the transmitters often radiate up to 50 Kilowatts, these frequencies are so far below the frequency of a wireless receiver, that the receiver front-end and IF filters can easily reject them. So, the theoretical signal of 185 MHz in this example is never actually generated in the receiver. 2nd order IM from two external sources like this rarely creates a problem in the receiver except in two unusual situations which are discussed later in this chapter in the section entitled “RFI IN SYSTEMS.”

“3rd order IM” can cause real problems that can not always be prevented by highly selective receiver front-ends. In the case of 3rd order IM, it is possible for the interfering signals to be simultaneously close together and close to the receiver’s operating frequency. In this case, the interfering frequencies will pass right through the front-end filters in the receiver and generate the IM signal in the first mixer.

3rd order IM can occur from the mixing of three signals, or from the mixing of a signal and a second harmonic of another signal. This primarily occurs in two places in wireless systems; at the first mixer in the receiver and between the transmitters themselves. If two transmitters are within several feet of each other, the transmitter output stages can mix the two signals together with very interesting results.

3rd ORDER INTERMODULATION

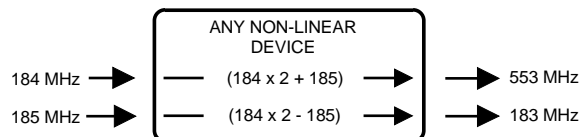

In this 3rd order IM example, the second harmonic of 184 MHz (368 MHz) mixes with 185 MHz, producing a signal at exactly 183 MHz. Obviously this is going to create a problem with the system at 183 MHz, since the 183 receiver will respond to this IM signal just as well as it will to its own transmitter. Radio signals will combine to produce IM signals through second, third, fourth, fifth, sixth, and even seventh order combinations.

Multi-channel wireless systems work reliably, however, after much time is spent in frequency coordination and optimum on-site antenna placements are made. The reliability factor improves dramatically if you use only high quality receivers designed for multi-channel environments. The performance specs on a receiver can be a bit nebulous, but among the most important specs for multi-channel capability are **selectivity** and **third order intercept**.

Selectivity is a specification that indicates the bandwidth of the receiver front-end filters and the IF filter stage. An excellent receiver front-end will exhibit over 20dB of suppression of RF signals at +/- 7MHz away from the carrier. IF filter performance is generally rated as a specified bandwidth between the half-power (-3dB) points either side of the IF frequency. The highest selectivity, fixed frequency receivers available have IF bandwidths of less than 50KHz and 60 dB of rejection at a bandwidth of 90 KHz. High performance wideband systems utilize wide deviation such as +/-75kHz, which requires that the IF filter bandwidth be several hundred kHz wide to avoid distortion.

“3rd order intercept” refers to the input level of interfering signals required to produce distortion (3rd order IM) of the same magnitude as the interfering signals inside the receiver. A fairly good receiver will have a 3rd order intercept spec of somewhere around -15dBm. The best receivers available will have a 3rd order intercept spec of +10dBm or higher.

RFI IN TRANSMITTERS

Obviously if two wireless systems are too close together in frequency (less than 400 KHz) they can generate audible interference in the receivers, or there will be a large reduction in the operating range of one or both systems. However, even transmitters that are widely separated in frequency can produce interference. Crystal controlled, non-synthesized transmitters produce not only the desired carrier but also a number of “spurs” (spurious emissions) at lower power levels above and below the carrier frequency. For a transmitter at 180.000 MHz there will typically be spurs at 15 MHz intervals on both sides of the carrier, namely at 135, 150, 165, 195, 210, and 225 MHz. Interference will occur in a receiver operating on or close to one of these spurious frequencies.

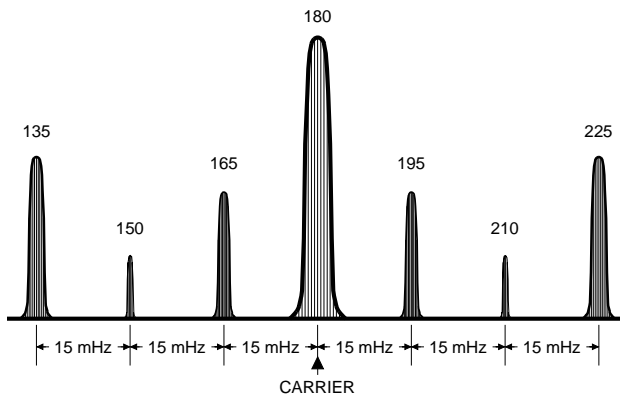

You can test for transmitter spurs by turning all the receivers on and then turning on one transmitter at a time. If two receivers come on at the same time, turn off the receiver that matches the transmitter and see if the other receiver remains on. If it does, you’ve probably got a spur from that transmitter. If the problem goes away when the transmitter is moved farther away, and the transmitter will always be used at that distance (or farther), you will probably be OK. High quality transmitters have output filtering that will reduce spurs, but it is difficult to eliminate them entirely. Proper frequency coordination is the best solution.

Transmitters can also produce interference if two transmitters are within several feet of each other. The RF signals can combine in a number of interesting ways, some of which can cause you real problems. Third order IM is one common problem. The other problem is overload of the output stage in one or both transmitters.

The symptom of 3rd order IM is interference in a receiver that is not on either of the two transmitter frequencies. For instance, transmitters on 183 and 184 MHz can generate interference in a receiver on 182 MHz, if the transmitters are within a few feet of each other. Since 3rd order IM is discussed in more detail in the section dealing with receiver problems, just remember that it can happen between transmitters as well as in receivers. Proper frequency coordination is always the best solution.

Another problem related to transmitters is caused by RF energy from one transmitter antenna coupling into the other transmitter antenna and causing output stage instability or overload. The symptom here would be one or both matching receivers squelching or producing very nasty noises.

If either of these symptoms occur between transmitters, your solution is to keep the transmitters farther apart or change frequencies on one (or both) of the transmitters. Moving the transmitter to the other side of a person’s body may solve the problem. Just remember to check this out, or a passionate embrace between two performers on stage may sound like “Robbie the Robot meets R2D2.”

RFI IN RECEIVERS

All wireless mic receivers operate through a process called “super-heterodyning.” A local oscillator inside the receiver generates a fairly strong signal that is mixed (heterodyned) with the incoming RF signal in the mixer stage of the receiver. The result is a “sum” and a “difference” signal. The “difference” signal (called the Intermediate Frequency or “IF” signal) is then heavily filtered and converted into an audio signal (demodulated). This process is used to lower the radio signal frequency to make filtering and demodulation much easier. For instance, a carrier at 194.7 MHz would be mixed with a local oscillator at 184.000 MHz to produce a standard IF frequency of 10.7 MHz.

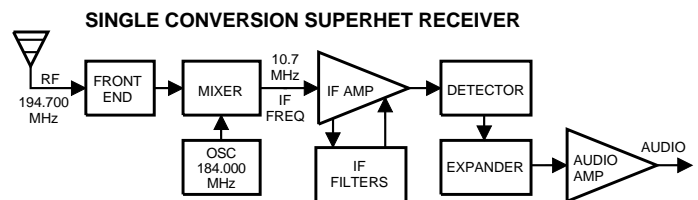

The oscillator in a superhet receiver can radiate energy outside of the receiver housing, usually through the antenna port. This radiated energy can easily enter another receiver located next to it, injecting the signal into the adjacent receiver. When this happens, the adjacent receiver can respond to signals from the first receiver. In other words, one receiver can generate interference for another receiver sitting next to it, even though neither transmitter is turned on. A 184.000 MHz receiver mounted in the same rack with a 194.700 MHz receiver can easily pick up the local oscillator from the first receiver as well as its own transmitter.

Through careful design, LO crosstalk like this can be minimized or eliminated altogether. The FCC regulates how much LO radiation is allowed, but the allowable tolerances are far above the low levels that can create problems in multi-channel wireless systems. A well designed front-end in a receiver is instrumental in minimizing LO radiation from the antenna port. A simple test of placing the receivers next to each other and observing the squelch indicators (usually labeled “RF”) will usually tell you if there is a problem with LO crosstalk.

The local oscillator in a receiver can also generate other spurious RF signals that are not as obvious as in the previous example. Most manufacturers of wireless receivers have chosen receiver operating frequencies that are compatible for multiple installations. Using receivers made by several different manufacturers in the same installation, however, may lead to some unpleasant surprises and lots of finger pointing.

You can test for LO crosstalk by hooking up the receivers exactly as they will be used (rack, audio cables, antennas, grounds, etc). Turn all the receivers on with all the transmitters off. If one or more of the receivers is indicating that it is receiving a signal, turn off all the other receivers. If the signal disappears, you probably have crosstalk. Then, try turning on the other receivers one at a time to locate the culprit. The simplest solution is to change the frequency of either the offending or the offended receiver or re-locate one of them. You will then have to try the same test again, of course.

RFI IN SYSTEMS (Rx/Tx combinations)

Second order IM is generally easy for a receiver to reject since the signals required to generate a problem must be far from the operating frequency of the receiver and can be easily rejected by the front-end filters. Remember that the frequency of a second order IM signal is produced by the simple sum or difference of the frequencies of two other signals. For instance, to generate an interfering signal at 185 MHz would require two signals either 185 MHz apart or two signals that would sum together to produce 185 MHz. Mathematically, at least one of the signals must be at least 92.5 MHz from the receiver's operating frequency (half the carrier frequency), which is easy for even standard front-end filtering to reject.

Second order IM can also be a problem if you have two transmitters that are separated in frequency by the IF frequency of the receivers (commonly 10.7 MHz). For instance, if you have transmitters at 185 MHz and 195.7 MHz, the difference is 10.7 MHz. This difference signal may interfere with any receiver with a 10.7 MHz IF operating within 5 to 10 MHz of these frequencies. For instance, a receiver at 193 MHz is only 2.7 MHz away from 195.7 MHz and only 8 MHz away from 185 MHz. A standard front-end may have only a few decibels of rejection for signals this close in and the signals will pass through the front-end to the mixer stage, which will generate a 10.7 MHz signal from these signals. Note again that it makes no difference what the receiver frequency is. As long as it is close to or between 185 and 195.7 MHz, it will have a problem with these two transmitters. Obviously, you don't want to have transmitters spaced at the IF frequency of any receiver in the system. Receivers with a highly selective front-end and high level mixers will help prevent this problem. Again, proper frequency coordination will alleviate this problem.

A subtle problem that can also occur in any multi-channel wireless system, no matter what operating frequencies are chosen, is similar to receiver crosstalk discussed earlier. Assume that two wireless systems are operating at 183.000 and 185.000 MHz (you can choose any pair of frequencies as long as they are within 10 MHz or so of each other). Assume that both receivers have IF frequencies of 10.7 MHz (the most commonly used). We'll designate the parts of these systems with 183 and 185 to keep them straight.

An example of this more subtle problem is illustrated below.

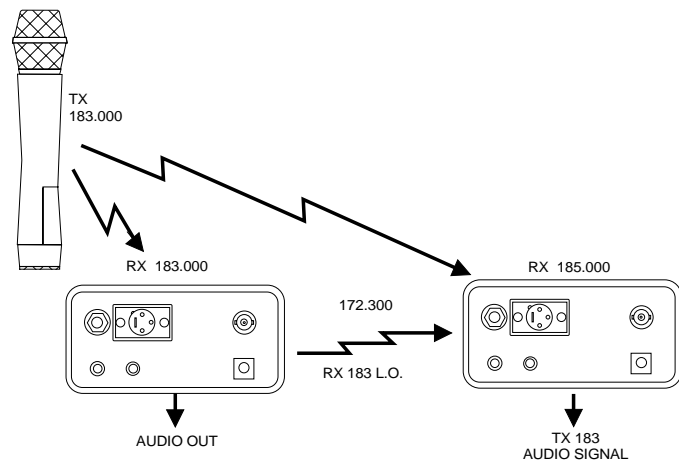

Receiver 183 has a local oscillator (LO) frequency of 172.300 MHz ($183.000 - 172.300 = 10.7$ MHz). If this local oscillator leaks into receiver 185 (which it can) there would appear to be no problem since any competent receiver can reject a signal 12.7 MHz off frequency. But, a problem suddenly appears anyway when transmitter 183 is also on. Transmitter 183's carrier and receiver 183's local oscillator combine in receiver 185's mixer to produce a 10.7 MHz signal ($183.000 - 172.300 = 10.7$ MHz). The problem is that both receivers will respond to the same transmitter, even though they are on different frequencies.

The reverse can also occur: receiver 185's local oscillator will be at 174.300 MHz and can combine with transmitter 185's carrier to produce a 10.7 MHz IF signal in receiver 183. In a well designed receiver, the local oscillator leakage will be minimal and this problem will only surface when the corresponding transmitter signal is strong. If the receiver has a high selectivity front-end, this problem will be further reduced. Since the two interfering signals are spaced apart by the IF frequency (10.7 MHz in this example), at least one of the signals will be attenuated by a high selectivity front-end.

To test for this problem, turn on all the receivers, positioned and connected exactly as they will be used, and turn on the transmitters one at a time. The transmitters should be about 10 or 12 feet away from the receiver antennas. The matching receiver will unsquelch (RF lamp comes on), of course, but watch for other receivers also unsquelching. If one or more other receivers unsquelch, turn off the receiver that matches the transmitter. If the other receivers then squelch properly when the matching receiver is turned off, you have this problem.

You can try moving the transmitter farther away. At the actual operating distances this problem may disappear. If it remains a problem at 30 feet or more, you may need to make major shifts in system frequencies. Small shifts will not solve this problem. If one receiver and matching transmitter cause all the problems, it is probably excessive local oscillator radiation from that receiver.

You can simply try replacing it with a different receiver and transmitter.

Some ways to reduce this problem are:

- 1) use antenna combiners that isolate the receiver antennas from each other
- 2) use receivers with low local oscillator radiation
- 3) use receivers with highly selective front-ends.
- 4) separate the receivers by several feet or more

Another basic problem that often occurs in multi-channel wireless systems is a matter of 3rd order combining of the carriers. To illustrate this problem, assume that you have wireless systems on 183.000, 184.000, and 185.000 MHz. The RF front-ends of the receivers will provide only a small amount of attenuation since there is only a 2 MHz spread between the

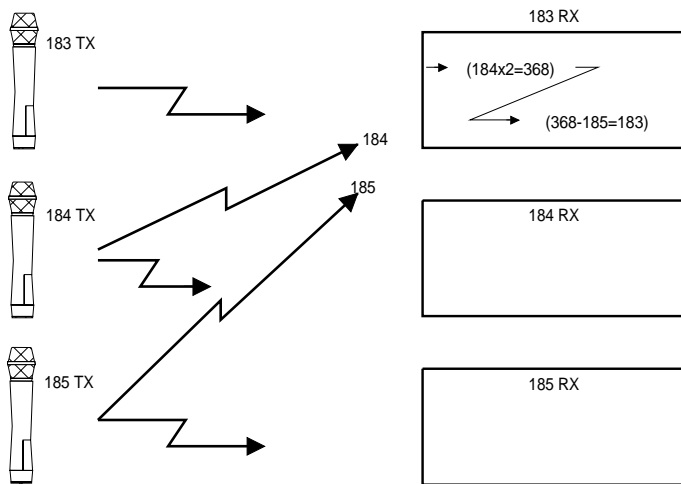

frequencies (1.2%). All these signals will pass through the front end filters of all three receivers.

Assume that the signal from transmitter 184 produces a 2nd harmonic (2×184 MHz) in the mixer stage of receiver 183. The signal from transmitter 185 (which also gets into receiver 183) is subtracted from the 2nd harmonic of 184, and the resulting signal is just as valid as the signal from the 183 transmitter.

$$(184.000 \times 2) - 185.000 = 183.000 \text{ MHz}$$

Obviously, you can prevent this problem by changing any one of the three frequencies. In a large multi-channel wireless installation, things aren't quite so easy to fix, since the possible combinations become mind boggling. In a 24 channel system there are 552 third order IM products. Changing one frequency to get rid of one interference problem can create 5 new ones.

If you also include the case of three transmitters getting into a receiver, the calculations become even more tedious and a computer program becomes absolutely necessary. To make matters even more unpredictable, the wireless system carriers can also mix with signals from external sources, or the external signals alone can mix to generate the same sort of IM problems. It is virtually impossible to predict all the combinations that could occur in any one locale. The best advice is to use only receivers offering very high IM rejection and very high selectivity. A computerized frequency coordination program is a must for any medium to large multi-channel wireless system of 6 to 24 channels.

SOLUTIONS TO RFI PROBLEMS

Since most multi-channel wireless mic systems utilize inactive television channels, the geographic location must be determined at the outset. TV stations in the vicinity must be taken into account first, followed by at least several "runs" of a computer program to determine what sort of IM problems might occur within a particular group of possible frequencies. The better computer programs include automatic selection and testing of frequencies within available bands, followed by a report of the results. In most cases, choices have to be made between the frequency groupings with the fewest overall IM problems, and the practicality of delivering what is available on time, given the particular sound system application. Even if you have some sort of computer program to do the calculations, there are still a number of choices and a few "judgment calls" that will need to be made. In addition, the particular filtering performance of each system must be taken into account.

Any wireless mic manufacturer who is truly involved with high-end wireless systems will have a computerized frequency coordination program available. In most cases, these programs are not available as "public domain" software since the parameters that make them valid change as the wireless systems are re-designed. There are thousands of calculations that must be made in order to select a group of frequencies that are useable for any particular location. This is why computers must be used. There is no way you could do all the calculations necessary by hand on a timely basis. Always contact someone with experience with this process and work out a frequency coordination scheme before you get involved with a multi-channel wireless system.

It is always best to implement a multi-channel wireless system using only identical systems from the same manufacturer on coordinated frequencies. Every wireless manufacturer has taken their own path in designing wireless systems. There are numerous choices made by design engineers to determine the oscillator fundamental frequencies, the multipliers to be used, and the IF frequencies in any particular design. Trying to mix different brands and models in a multi-channel system is just asking for problems. Putting 3 or 4 channels into a church in Buford's Point, Idaho is one thing. Trying to place 8, 10 or more channels on the road touring the US is an entirely different matter.

Synthesized, frequency selectable wireless systems can facilitate the frequency changes needed to achieve a compatible grouping of frequencies in a particular situation, but there is also a "dark side" to this agility.

Synthesized transmitters typically generate fewer and lower spurious emissions, which eases the complexity of coordination a bit, but the problems of crosstalk and intermodulation just discussed will still exist. Imagine a crowded news gathering event with a dozen or so wireless systems operating. Obviously, there is no time to get everyone together and work out a useable frequency mix. Even if you could, a late arriving crew may bring in yet another frequency and create the need to do it all over again. If everyone using a frequency selectable system starts switching around at random to find a clear channel, the odds that you end up with a compatible mix in a reasonably short length of time are slim to none. Frequency selectability in this scenario may well make things worse.

COMPUTER INTERFACE

With the advent of microprocessor control, a powerful tool is now available in high-end receivers offered by Lectrosionics to assist in identifying RFI and find clear operating spectrum. The software supplied with the receiver provides a graphical display of all internal settings and status, and enables downloading and uploading frequency groups to and from the receiver, as well as adjustment of a variety of operating modes. Utilizing an RS-232 compatible PC interface for the Windows® operating system, the receiver can be also used to perform a “site scan” when setting up a wireless system in a new location.

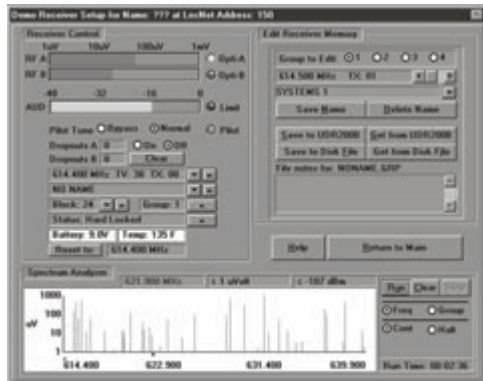

The lower section of the display provides a graphical, scanning spectrum analyzer for conducting site surveys. During scanning, the receiver is tuned in steps across its tuning range and markers are placed on the screen to indicate the frequency and signal strength of signals found. The advantage of using the receiver rather than separate test equipment for scanning is that the receiver will display not only external signals in the vicinity, but also RF signals produced by intermodulation that might occur inside the receiver. The result is a thorough analysis of the site, and a clear picture of the usable spectrum available.

TESTING FOR COMPATIBILITY

In the “real world,” a touring sound company can rarely enjoy the luxury of purchasing or renting a new collection of wireless mic systems each time they move to a new location and implement a multi-channel wireless system. It would be nice to go through all the steps and check out procedures previously mentioned for each job, but the real world just isn’t that friendly. The following procedure is useful in determining the basic compatibility of a multi-channel wireless system, both for touring sound companies and in fixed sound applications.

1) CHECKING FOR RECEIVER INTERACTION

Turn on all receivers and place them in the same relative position they will be in in actual use. Leave the transmitters off. Check to see if any of the squelch indicators (usually labeled “RF”) on any of the receivers light up. If any receiver squelch opens, turn off the other receivers one at a time to locate the receiver generating the RFI signal. By repositioning the offending receiver, you may be able to alleviate the RFI problem which, in this case, could be the result of LO crosstalk.

If repositioning the receivers does not change the problem, you may have an external RF signal mixing with one of the receiver oscillators. In this case, turn on the transmitter for the receiver that the squelch opens on, and see if the audio sounds OK. If the

external signal is fairly weak, the transmitter signal will bury it and the system will still operate OK. A strong external signal, however, can create noise even when the receiver’s own transmitter is on.

2) CHECKING FOR TX SPURS AND 2ND ORDER IM

Turn on all the receivers. Then, turn on the transmitters one at a time. As each transmitter is turned on, its corresponding receiver will unsquelch (RF lamp comes on). Look to see if any other receivers also unsquelch at the same time. If one or more others does come on, turn off the receiver that matches the transmitter and see if the other receivers remain unsquelched. If the squelch remains open, then you probably have a transmitter spur getting into the other receivers. If they squelch and shut down normally when the matching receiver is turned off, you may have a 2nd order IM problem as was discussed in the text earlier in this section entitled “RFI IN SYSTEMS.” Refer back to that text for more information on this type of RFI problem.

3) CHECKING FOR 3RD ORDER IM

Turn on all receivers and all transmitters. Place the transmitters at the closest distance from the receiver antenna/s that they will be in during actual use. One at a time, turn the transmitters off, and then back on again. Do this at least 5 or 6 times for each transmitter as you move around. Moving around with the transmitters as you turn them off and on will insure that you don’t have one located in a “null” where the RF signal is very weak at a receiver where you would normally have a problem. Check to see if the corresponding receiver squelches (no RF lamp) as its transmitter is turned off. If it doesn’t, you will need to determine what combination of transmitters creates the RFI signal.

Through what can sometimes be a rather lengthy process of elimination, you can narrow down the problem and identify which particular combination of transmitters generates the offending IM signal. The solution to this type of IM problem often involves changing frequencies of one or more of the systems. Sometimes, moving the receiver antennas farther away from the transmitters can reduce the IM problem.

4) FINAL SYSTEM CHECK OUT

Turn everything on. Listen to the output of each system one at a time. The idea in this step is to check for bad connections, transmitter gain adjustments and receiver output levels.

FREQUENCY COORDINATION

Interference is never considered acceptable in wireless microphone systems, yet it is not all that uncommon. When interference does occur, it is embarrassing, disruptive and annoying. For audio professionals responsible for wireless systems, it also usually means costly trouble. Yet, most problems with wireless interference are preventable. Only in a relatively small percentage of instances is the interference truly unavoidable. The fact is that most interference is caused by other wireless systems, broadcast transmitters, handi-talkies and other known or controllable sources. With an early start and an orderly approach, simple measures can be taken that will greatly reduce the chances of interference.

Frequency coordination is a procedure for ensuring, in advance, that predictable causes of harmful interference are avoided. Whether or not each of these sources is a potential cause of interference can be analyzed mathematically and, if so, appropriate preventative measures taken. The analysis can, and often does, begin before the wireless equipment is even purchased. If supplied with adequate information about the location of the site, about other wireless systems at the site, and details on other radio equipment present at the site, the wireless dealer or manufacturer can select optimum operating frequencies for the new equipment.

SYNTHESIZED WIRELESS SYSTEMS

At first glance, it might appear that use of synthesized wireless equipment would eliminate the need for frequency coordination and analysis. In a few instances, such as for a small number of systems that are all under control of one or two team members, this will be true. In these cases, the team will usually be able to turn on all of the equipment and find interference-free frequencies by trial and error. Even this has some pitfalls, however, since it might be difficult to fully recreate the complete RF environment during testing. In addition, intermodulation levels depend greatly upon the actual signal levels present, and moving just one transmitter a few feet closer to a receive antenna might introduce a number of additional problems.

In more typical situations, the use of synthesis not only does not eliminate the need for coordination, it can make the task more difficult. In many broadcast and production environments several different production groups might be operating wireless systems in close proximity to each other. If one group takes it upon themselves to change the frequency of a system, it is not unlikely that the change will suddenly introduce problems into the systems in other wireless systems, or on adjacent stages. If the second group then changes the frequency on one or more of their systems, a third group or the first group might well now experience problems. Without some control and discipline, it is easy to see how the situation can escalate out of control, wasting large amounts of expensive production time.

A typical compromise is to find a small number of additional trouble-free frequencies for each of the groups. If a change is then desired, the new frequency is selected from the supplemental list, providing a reasonable degree of assurance that other groups will not experience new problems. The difficulty is, of course, that finding enough extra good frequencies can be extremely tough and the task will certainly require much additional effort. Most facilities eventually adopt some type of centralized control in order to minimize conflicts.

This is not intended to downplay the value of synthesized wireless systems. The flexibility of being able to retune a system to replace a failed or unavailable system, the ability to go to other cities having different TV channels, increased equipment utilization and many other benefits make such synthesized equipment deservedly popular. The point being made is that there are many situations where use of synthesized gear, if not properly controlled, can cause as many problems as it solves. A crowded news gathering event is prime example.

PROGRAMS AND TOOLS

As was discussed above, computer programs are more or less essential in performing frequency coordination. Virtually all wireless manufacturers use such programs at least occasionally. Often, however, manufacturers do not make them available to their dealers and customers, since the data required for valid calculations is changing constantly, and specialized training is required to correctly analyze the results of the calculations. If a suitable program is not available to the user, how then is frequency coordination accomplished?

There are several choices. Many wireless manufacturers will perform frequency coordination for new systems being purchased, usually including existing wireless equipment from other wireless manufacturers. Many dealers offer the same service. If more than one brand of equipment is being used, perhaps one manufacturer will provide this service even if the other will not.

There is a significant element of risk, however, with using a program from one manufacturer with equipment from another. Maintaining accurate data from several manufacturers to include all of the subtle sources of potential RFI in a single database is virtually impossible. Since a particular program might or might not be usable for other brands of wireless equipment, its suitability should be verified with the technical staff of the manufacturer. Otherwise, there is a good chance that the results obtained will be seriously in error.

A few dealers and wireless service centers offer frequency coordination and related services on a fee basis. This may be a good choice if the equipment manufacturer and dealer does not provide the necessary support. This type of support might also be available at night and on weekends, an option not generally available from manufacturers. It is suggested that the wireless manufacturer or dealer be contacted to see if they can provide such services, or can make a referral to someone else qualified to do frequency coordination.

Third party "intermod" programs are available from several sources, both commercially and as shareware. The commercial programs tend to be relatively expensive. The quality of the shareware programs is extremely variable, often making invalid assumptions about equipment characteristics. In both cases, these programs often do not test for certain significant types of wireless interference. At the same time, they might identify "problems" that do not really exist, such as very high order intermodulation products. Use of these programs is best left to persons familiar with both wireless systems and the technology involved.

It should also be observed that an appropriate level of support from the manufacturer, dealer or service supplier could, as a practical matter, prove to be a necessity. That is, if situations that require frequency coordination are relatively common, and needed support is not readily available, it might be wise to consider another supplier. A wireless system that doesn't work properly, at any price, is never a bargain. Faulty frequency selection can be every bit as damaging as an equipment failure.

In addition to an appropriate computer program, other data is required in order to perform an accurate coordination. Two particular pieces of information are especially important; the active TV channels in the area of use, and the frequencies and types of all other wireless systems and RF equipment that will be at the location. In a majority of applications, wireless-to-wireless interference is the most common form of troublesome interference. It is also one of the easiest to avoid. Simply providing the computer program with the frequencies and types (or characteristics) of all wireless at the location will allow it to select interference-free frequencies 98% of the time.

The importance of including all equipment to be used is difficult to overstate. Just one extra wireless transmitter at the location can, and often has, resulted in serious problems with a considerable number of other wireless systems. Obviously, this also applies to systems added at the last minute, or any changes to the coordinated frequency list (including resetting a synthesized system). Basic information, such as manufacturer, model number and frequency about other wireless systems in use is also required. This includes such items as wireless intercom systems, wireless IFB equipment and wireless musical interments. Without this information, the programs cannot prevent the possibility of certain types of interference to these other systems.

Basic information on other RF sources at the location is also needed. This includes portable two-way communicators, CATV or MATV systems, data and telemetry transmitters and similar items. Transmitters on frequencies below 108 MHz or above 1000 MHz can almost always be safely ignored unless they are extremely powerful. Gathering this data is not always easy, especially when the site is in a distant city and the inquiries must be done by telephone, e-mail or fax. However, obtaining accurate information is the only real way of avoiding nasty surprises a half-hour before a live performance.

Channel numbers for local TV channels are also needed. Often, manufacturers and dealers will have this information available from reference documents and only the city of operation will need to be specified. It is almost impossible for the references to be totally up to date, however, so an inquiry as to whether any new TV channels have gone on the air in the city within the last month or so is advisable. This is mostly a problem at UHF frequencies since relatively few VHF stations are still being constructed. The advent of DTV has worsened this situation. Unfortunately, accurate and up to date TV information is not easy to obtain and can be relatively expensive, so a local contact is usually the best source.

Only high band VHF TV channels numbers are needed if only VHF wireless systems are being used. If UHF wireless systems or a combination of VHF and UHF systems are to be used, both UHF and high band VHF TV channels might be required. Do not leave out public and educational TV stations, which are

sometimes omitted from published listings or appear only in small separate sections of a publication.

SITE SURVEYS

Sometimes the question of doing a site survey is raised. The idea is that suitable monitoring instruments be brought to the location and "all of the signals" that could interfere with the wireless will be found. While the sentiment is understandable, especially if there have been recent interference problems, this approach is not very reliable. The problem is that many potential interference sources only operate intermittently; two-way radio being a common example. Readily available monitoring instruments are not suitable to capture and record information on very brief random transmissions and human monitoring is highly error prone over any extended period of time.

Other difficulties include the inability of reasonably priced instruments to determine and record the exact frequency of a source; an essential part of using the data in a coordination program. An error of only 10 to 25 kHz can make the difference as to whether or not a specific source is likely to be an actual problem or just a near miss. Also of concern is that the wider the frequency range to be monitored, the longer it will take. This is a serious limitation if more than a 3 or 4 MHz bandwidth needs to be checked. Finally, sources at the site itself are most likely to be a problem, and they might not ever be operated until the event takes place. Good examples are portable communicators for security personnel and special tactical two-way frequencies used by police details.

The most serious limitation of all is that much of the interference experienced by wireless systems is due to intermodulation that occurs inside of the wireless receivers. In this case, there not be an actual RF signal at the proposed wireless frequency that could be detected by a separate instrument. Thus, the idea of "searching" for good frequencies with an instrument is more or less unworkable. Considering these shortcomings and the typically high costs for site surveys, it is necessary to question both their accuracy and whether or not they are cost effective.

Despite the above, there are a few situations where a simplified on-site survey can be of value. One example is when the wireless systems will be used at a considerable elevation, such as on the top floors of a tall building or on a hilltop. In this case, strong signals from TV stations or other transmitters at surprisingly great distances are sometimes encountered. Another example is when wireless systems will be used near military or government installations or high power radar sites. Special purpose government equipment sometimes uses frequencies that can interfere with wireless microphone equipment, but this is rarely public knowledge.

High power radar systems such as that used by the military and the aircraft traffic control network can also be troublesome, especially near airports and remote radar sites. In most cases, the interference is not due to frequency conflicts, but rather the circuit effects of very high power microwave signals. This can be a difficult situation to resolve, making early warning of the problem very important. Another somewhat similar situation occurs in and around heavy industrial areas. Here, high power electrical equipment can cause various types of interference problems, especially at VHF frequencies. A relatively quick

survey will usually be adequate, but care must be exercised to ensure that testing is performed at the appropriate time of day and day of the week.

The bottom line is that site surveys with test equipment can be worthwhile in certain circumstances, but lengthy and elaborate surveys have little more value than simpler ones. In addition, the limitations of surveys should be kept firmly in mind in order to avoid placing too much faith in their results. The best approach is to use the actual wireless receivers that will be used in the venue to conduct a site survey, so that all IM products will be included in the results.

INTERNATIONAL COORDINATION

The basics of performing coordination are the same in all locations, but there are some practical concerns. One is that the computer programs normally used in the US might not be valid for locations outside of the US and Canada. Many such programs have TV channel data coded directly into the program. This data is invalid for many areas of the world, as TV standards and exact channel frequencies vary significantly from country to country. Wireless equipment technical standards also vary significantly from country to country, so the version of the program available might not provide accurate results when used with wireless equipment intended for use in other countries. Also keep in mind that wireless mics are still illegal in some countries and heavily restricted in others; just because the equipment can be made to work in these areas does not mean that it will be legal. For example, the eight special VHF “traveling” frequencies from 169 to 172 MHz popular in the USA are not available in most other countries, even Canada. In most areas, this frequency range is set aside for government communications and private use is highly discouraged.

Obtaining the required information might be more difficult due to language barriers and terminology differences. Despite the problems, full and complete information is still essential if trustworthy results are expected. TV channel information is often especially difficult to obtain.

SOME GENERAL SUGGESTIONS

Here, in no particular order, are a few suggestions regarding frequency coordination and management of wireless systems:

- Always ask for frequency coordination when purchasing new systems.
- Obtain the support of the equipment manufacturer or dealer if reasonably possible.
- Don’t attempt to go without coordination even if support is difficult to obtain.
- For all coordination, provide as much and as detailed information as possible.
- Be aware of all wireless equipment brought to the site, even on a temporary basis.
- Rerun the coordination any time additional RF equipment is to be used at the site.
- Have a plan for a usable backup if equipment is lost, stolen, damaged or simply fails.
- Keep the pertinent data readily available in case last minute changes require rechecking the coordination.
- Keep TV channel data up to date and close at hand.
- Always keep in mind that just one new RF source can invalidate the entire coordination.

A final observation is in order. This is that frequency coordination works extremely well in avoiding problems from frequencies that are known and have been considered by the computer program. The process does not offer any protection from RF signals that were not evaluated by the program and interference from such signals is entirely possible. Sometimes local RF sources are simply overlooked when the list is compiled or have gone unnoticed for one reason or another. More often, the problem is due to equipment that has been introduced to the site after the frequency list was prepared, illustrating once again the need to be aware of all RF equipment at the operating location.

It is an unfortunate fact that on rare occasions RF signals appear that simply should not be there. Sources for these signals include special government equipment, unapproved digital and computing devices, defective commercial communications equipment and illegal RF devices of various types.

The best protection against problems due to these unexpected interfering signals is to use only high quality wireless equipment and complete the sometimes arduous task of a complete system check out as outlined earlier in this chapter. The best results will be found with receivers that offer overload-resistant RF circuitry, tight RF and IF selectivity, and optimized demodulators and audio filtering. Very often, high quality wireless equipment will operate flawlessly in the face of interference that renders less capable systems useless. For critical applications, an investment in high quality professional wireless always pays handsome dividends over the long term.

MULTI-CHANNEL WIRELESS SYSTEMS

Given the problems of IM and interference discussed in the section entitled INTERFERENCE and FREQUENCY COORDINATION, it should become apparent how complex a multi-channel wireless system really is. The receivers must be designed for a multi-channel environment or you can expect problems from both internal and external RF sources.

RF/POWER DISTRIBUTION

From a practical standpoint, multi-channel wireless systems must provide some means of “stacking” the receivers together and sharing common antennas. Simply stacking up a bunch of receivers next to each other with separate antennas can create a number of problems. Superhet receivers radiate RF energy from the antenna ports and, in some cases, even radiate RF energy right through the housings. The radiated energy is normally at the oscillator fundamental frequency or at a harmonic multiple of it. When receivers are placed next to each other, they can interact with one another, unless they are isolated by some method.

Distributing the output of a single antenna to two or more receivers is a bit more complicated than it may first appear to be. First of all, as the signal is divided, the individual signal sent to each receiver becomes weaker. This means that an RF amplifier is needed in order to keep the signal level at each receiver high enough to provide a usable signal to noise ratio. The RF amplifier can also amplify unwanted out of band signals unless it is preceded by some sort of filtering. Lastly, by connecting the receiver antenna terminals together, RF interaction between the receivers will occur unless some sort of isolation is provided.

So, an effective multi-channel RF “coupler” should include the following features in the order listed:

- 1) Front-end filtering
- 2) Low noise RF amplification
- 3) Low loss, high isolation RF splitter

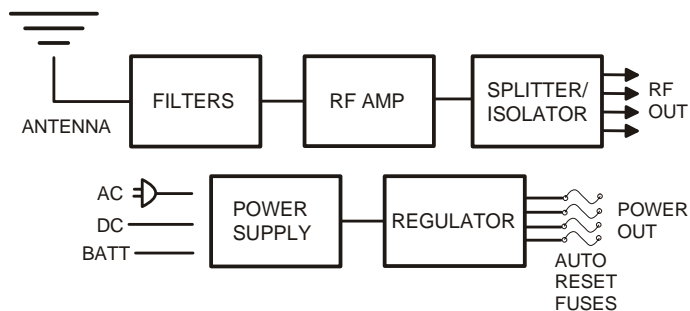

This diagram depicts a single antenna multi-coupler. A diversity multi-coupler will include a second, discrete RF path for the additional antenna. Compact multi-couplers for field production usually include DC power distribution. Larger multi-couplers, such as an 8-way diversity type, normally include only RF signal distribution.

Another valid approach to designing a multi-coupler consists of using a very hefty RF amplifier that has a very high overload threshold (third order intercept of +40dBm or so) without filters. IM products in this type of design will be minimal, but the power consumption of many high level RF amplifiers often precludes this approach in compact units designed for field production where battery power is the only option.

MECHANICAL ASSEMBLIES

It is generally good practice to keep power cables away from signal cables in any installation. If each receiver has its own power cord, it often requires some careful routing of the cabling in the rack or transit case to avoid AC hum induced in the audio cables. This is where using low voltage DC powered receivers comes in very handy. If the RF distribution module also includes DC power distribution, you easily can put together very effective multi-channel receiver assemblies without creating additional complexities.

OPERATING RANGE

As a general rule, it is good practice to install the receiver antenna/s so that a transmitter cannot come within less than 25 feet or so of it during the performance. The closer the transmitter is to the receiver antenna, the stronger the RF signal will be and the more prevalent the IM products. Of course, if the transmitters are too distant from the receiver, there is also the risk of dropouts. So, the best approach is to set up a multi-channel wireless system so that the transmitter to receiver antenna distance falls within a targeted “window.” Generally speaking, a good “window” for system check-out (and even operation) is not over about 100 feet and not less than about 25 feet. The upper and lower limits of this “window” will vary, of course, depending upon the performance characteristics of the exact equipment being used.

This “window” of distance cannot be maintained in what might be called an over-shoulder “bag system” that consists of several receivers and a portable mixer, with the mixer output feeding two transmitters that are also located in the bag. The use of a compact, battery powered multi-coupler in this type of setup is convenient and helpful in dealing with RF interaction between the receivers and transmitters. Because of the close proximity of the output transmitters to the receivers, however, extreme care must also be taken in frequency coordination to ensure that the system does not interfere with itself. Generally speaking, a wide separation in frequency between the receivers and transmitters is mandatory, as is the “final system check out” procedure outlined later in this chapter and in the section of this guide entitled INTERFERENCE and FREQUENCY COORDINATION.

FREQUENCY COORDINATION

It should go without saying that any multi-channel system of more than 4 or 5 channels should be carefully planned. Larger systems with 10 or more frequencies can have all kinds of problems with intermodulation, crosstalk and noise. Computer programs are mandatory in planning the frequencies for larger systems, as well as providing a “starting point” before going through a check out procedure for any multi-channel system. Every manufacturer who is a real “player” in the high-end wireless market will have and use a computer program to predict frequency compatibility in multi-channel systems. Many dealers and specialized consulting firms are also available to perform frequency coordination. Since proper planning involves thousands of calculations and a considerable amount of time, there is sometimes a fee for providing this service.

MIXING DIFFERENT BRANDS OF EQUIPMENT

It is hard enough to come up with usable frequency mixes for larger multi-channel systems using all identical receiver and transmitter models, but the process becomes much more difficult when various models and brands are used. Computerized frequency coordination programs include calculations that take into account the IF frequencies, oscillator fundamentals and harmonics and several other aspects of the transmitter and receiver designs. By mixing different brands and models together, it is almost impossible to predict all the signal combinations that can occur.

LONG ANTENNA CABLES

The primary problem with long runs of antenna cable is loss of RF signal through the attenuation in the cabling. It is best to keep antenna cabling down to a minimum as a general rule. In some installations, however, it may be necessary to run cabling to remote locations in order to place the antenna within the proper distance “window” mentioned above (see previous paragraph on OPERATING RANGE). Different types of coaxial cable exhibit different amounts of attenuation. Check the specs on the cabling you intend to use and see how much signal loss would occur.

By positioning the antenna closer to the transmitter, a stronger RF signal can be picked up at the receiving end of the antenna. The additional signal that is picked up, however, may be lost in the attenuation in the cabling. There is a point where you lose more signal through the cabling than you gain by positioning the antenna closer to the transmitter.

For example, RG-8 or RG-213 are two common types of coaxial cables used for UHF frequencies that have a loss of 7 dB per 100 feet. If the antenna is going to be 25 feet from the performer, the signal level at the antenna will be at -30 dBm on the average. If a $\frac{1}{4}$ mile (1320 feet) of cable is used between that antenna and a receiver, then the signal level at the receiver will be 93 decibels less or -123 dBm at the receiver. This is much less signal than that required to be even detected, let alone be usable.

For comparison, if we don't use a cable at all but just broadcast from the transmitter to the receiver through the air, the loss is 6 dB for each doubling of distance. Now the signal at a $\frac{1}{4}$ mile will be 36 dB lower than at 25 feet. The signal at the receiver will be -66 dBm on the average and the reception will be quite good. To do a ridiculous comparison, a full mile of RG-8 cable will have a loss of 369 decibels and would require 457 trillion trillion Watts of power at the antenna end of the cable to produce enough signal to be usable at the receiver end. This would run a 9 Volt down pretty quickly.

For shorter runs, coaxial cable can offer some improvement in reception. A 100 foot run of cable, for instance, is better than broadcasting through the air. Going through the air, the signal would be -42 dBm at the receiver and using a cable the signal would be -37 dBm at the receiver, a 5 dB improvement using the cable. Of course, sometimes cables must be used such as when the receivers are mounted in a metal rack, or are located in a control room that will shield the receivers from the antenna. The purpose of this discussion is to illustrate some of the pitfalls in long cable runs.

A unique tool is available from Lectrosonics for dealing with long cable runs. The UFM50 filter/amplifier is a compact device that includes ceramic resonator front-end filtering and a high quality RF amp in an in-line device with jumperable gain settings to compensate for losses incurred in long coaxial cable runs.



The UFM50 can be powered by external DC power at the connector on the housing, or DC power present on the BNC output jack provided by high quality, rack mount multi-couplers.

THE UFM50 AS A MULTI-COUPLER

The UFM50 can also be used to implement a high performance, compact multi-coupler when used with a high quality, passive splitter. The input of the UFM50 is connected to the antenna, with the output connected to the input of the splitter.

High quality passive splitters, such as the one shown here, are specialized devices offered by only a few companies, yet they are readily available through radio communications companies or, of course, from Lectrosonics.

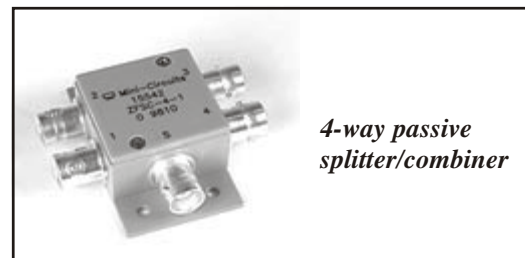
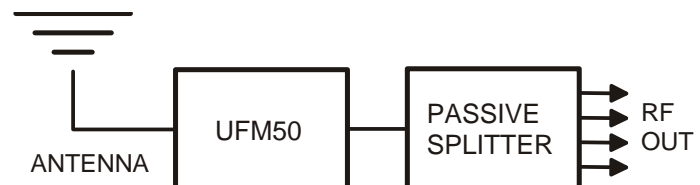

ANTENNA BANDWIDTH

The frequency bandwidth of the antenna becomes a consideration when a single antenna is used to feed an RF distribution system. The main concern is that the receivers connected to the antenna are on frequencies within the bandwidth of the antenna. Even if a receiver frequency is close to the edge of the antenna bandwidth causing some loss of signal (3 to 6dB or so), the slight loss of RF signal is usually not a problem. When the wireless system is being operated near the limit of its range or severe with severe multi-path conditions, however, it is good to gather every bit as much RF signal as possible. Minimal cable loss in this case could make the difference in whether or not the performance of the system is acceptable.

FINAL SYSTEM CHECK OUT

The check out procedure outlined in the chapter on INTERFERENCE should be a standard routine with any multi-channel system. The process first checks for receiver crosstalk with receivers on and transmitters off. Then the transmitters are turned on one at a time to check for 2nd order IM. Next, all transmitters are turned on and then turned off one at a time to check for 3rd order IM problems.

Lastly, everything is turned on and the audio output of each system is monitored one at a time to check for bad cables, level settings, intermittent connections, etc. This check out procedure should be followed any time two or more wireless systems are to be operating simultaneously in the same room.

RECEIVER MULTI-COUPLERS

COMMON TYPES OF MULTI-COUPLERS

To facilitate the ever increasing demand for more wireless mic channels in a variety of applications, a number of high performance multi-couplers are now available to combine multiple receivers into convenient assemblies. Multi-couplers are available in a variety of different configurations to provide RF distribution only, RF and power distribution, as well as complete systems that provide RF and power distribution and a mechanical assembly to mount the receivers.



Rack mount 8-way diversity RF multi-coupler

For high-end studio and stage applications, a number of companies offer antenna multi-couplers for the convenience of sharing antennas with up to 8 receivers. A high quality multi-coupler such as this generally provides only RF signal distribution, and will normally offer 110 to 240 VAC or DC powering, front-end filtering, a high overload point RF amplifier and highly isolated RF outputs. The unit pictured here offers ceramic resonator filters with a 50MHz bandwidth, and a transmission line ("strip line") isolator/splitter.



Four channel rack mount RF/Power multi-coupler

For use with a variety of compact VHF and UHF receivers, Lectrosonics offers an assortment of UHF and VHF rack mount multi-couplers for compact receivers that includes RF and power distribution as well as a 19" rack mount mechanical assembly.

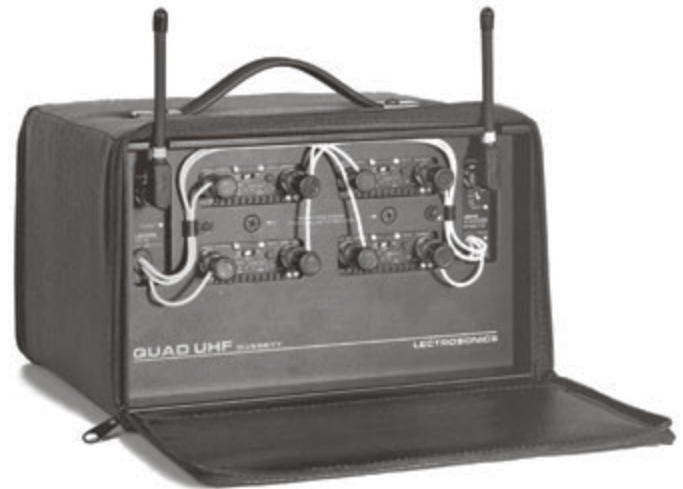

UHF Quad Pak RF/Power Multi-coupler

This is a specialized type of multi-coupler used in motion picture production for location recording with compact receivers. Two distribution modules are provided for diversity receivers, one module includes power distribution and battery charging circuitry, and the other is for RF distribution only. A built-in, high capacity, rechargeable battery pack provides power for up to 12 hours of operation per charge, or the system can be powered by external DC.

The antenna multi-couplers in the distribution modules offer front-end filtering with a 50 MHz bandwidth, a high overload point RF amplifier and transmission line ("strip line") splitter.

The distribution modules can be removed for use separately, such as in an over shoulder bag system or sound cart. The modules are powered by 12 to 16 VDC.



The main distribution module includes a high quality RF multi-coupler and DC power distribution with discrete auto-reset polyfuses for up to four receivers.



The "slave" module will work separately as a high quality, compact RF multi-coupler for field production.

SIGNAL TO NOISE RATIO

The RF signal level at the receiver antenna varies wildly as the transmitter moves around, due mostly to multi-path and overall distance from the transmitter to the receiver. The background RF noise in the environment also fluctuates. RF noise or interfering signals can produce hiss, buzzing, whistles, whining, etc. Normally, the background noise in the system is low enough that it is masked by the audio signal, but when the RF level from the transmitter dips low enough or the background noise in the system gets high enough, noise can become audible. There are several different factors which affect the signal to noise ratio of a wireless system.

Drop outs or noise can result from problems with any one or more of these factors:

- 1) Transmitter input gain too low
- 2) Transmitter to receiver distance (operating range) too great
- 3) Environmental RF noise near the receiver antenna
- 4) Multipath phase cancellations at the receiver antenna
- 5) Obstructions in the path between the transmitter and receiver antennas

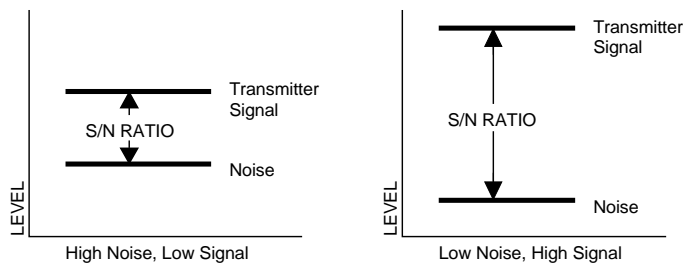

TRANSMITTER TO RECEIVER DISTANCE

The transmitter to receiver distance has a major effect on the signal to noise ratio of a wireless system. As the transmitter moves farther away from the receiver, the overall signal to noise ratio grows worse as the transmitter signal gets weaker. When the system gets near the limit of its operating range, drop outs will become more frequent and a buildup of steady background noise (hiss) may be audible.

There is a significant difference in various receiver designs with respect to the quieting slope. Quieting slope is a measure of the ability of a receiver to achieve full signal to noise ratio at weak RF levels. A high quality, narrowband receiver will typically achieve full quieting with only a few microvolts of RF signal. Low cost, wideband designs require many times more signal to achieve full quieting. Of course, there are many factors in the design of a receiver that affect the quieting capabilities, but all other factors aside, a narrowband receiver has an inherent advantage in that the sharp filtering in a narrowband design gathers less noise from the operating environment. The “operating environment” includes digital video cameras and recorders where the receiver is often mounted directly on the camera or connected to the recorder input.

TRANSMITTER INPUT GAIN

The transmitter input gain is the single most important adjustment on any wireless mic system to insure an optimum signal to noise ratio. The audio signal to noise ratio will never be any better than it is at the transmitter input. If the input signal is noisy at the transmitter, there is nothing else that can be done later to restore it to its original quality. The audio level is adjusted with the gain control on the transmitter, while watching some sort of level metering on either the transmitter or receiver.

The most difficult problem with properly adjusting the transmitter input gain involves duplicating the user’s voice level in advance of the actual performance or use. Obviously, you need some sort of metering in order to correctly set the transmitter input gain. The metering must indicate the modulation level of the radio signal and also limiting in the transmitter. Metering is generally provided on the receiver, but often times the transmitter metering is easier to use, since the receiver may not be accessible or visible from the transmitter location during setup.

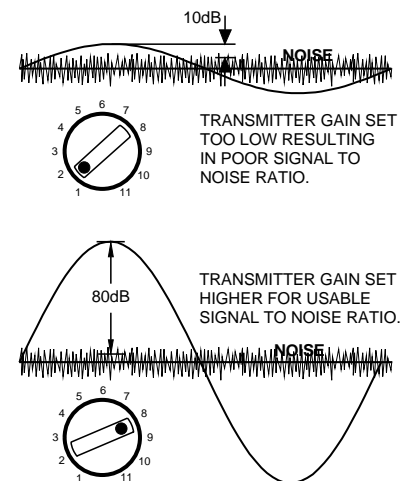

OTHER CAUSES OF NOISE AND DROPOUTS

Obstructions in the path between the transmitter and receiver antennas can also increase audible background noise. An obstruction in the direct path between the transmitter and receiver antennas causes the same effects as increased operating range (a lower incoming RF signal.)

Multi-path phase cancellations at the receiver antenna can make the background noise audible briefly. This is a drop out, as is discussed in more detail in the section entitled **DIVERSITY RECEPTION**. When a phase cancellation between direct and reflected RF signals occurs at the receiver antenna, the desired signal from the transmitter may not be strong enough to bury the background noise. This problem is also referred to as a “noise up.”

Environmental RF noise near the receiver antenna is another cause of poor signal to noise ratio. Digital switching devices, power supplies, etc. can radiate broadband RF noise. If a noise source like this is located near the receiver antenna, the net effect is that the noise floor is raised by the amount of RF noise. In other words, the signal to noise ratio of the wireless system is lowered by the added RF noise.

RECEIVER ANTENNA PLACEMENT FOR A RELIABLE RF LINK

Monitoring audio signal levels is fairly simple, however, RF signal levels are much harder to measure and evaluate. Aside from this fact that, they also change constantly. Add to this the fact that there are many more RF signals hitting the receiver antenna than the single signal coming from the transmitter. Many of these additional RF signals are almost impossible to predict.

Some receivers offer RF level metering. This is very handy in determining the overall RF signal strength. You will have to conduct a walk test, while viewing the RF level meter. If the RF level dips to a low level when the transmitter is in a particular location, reposition the receiver antenna to a new location at least several feet away from where it was when the drop out occurred.

The antenna location that produces the strongest RF signal level is not necessarily the location that will produce the best signal to noise ratio. The reason for this is that in some installations the antenna may be positioned close to an RF noise source (synthesizer, switching power supply, computer, etc.) and the additional signal strength indicated by the RF level meter may be composed largely of RF noise. Again, a walk test and close listening to the audio output will reveal which location is best.

Even if you can utilize some very expensive RF test equipment to evaluate the environment where the system is located, it will still be impossible to predict RF interference from external signals that could appear later. The best insurance against interference problems is to use only high quality, high selectivity receivers for any critical application.

INTERPRETING WIRELESS MIC SPECIFICATIONS

Specifications for any product always fall subject to whatever parameters are typically used in the markets where the products are sold. The “spec game” is played by every manufacturer. The allowable tolerances are not strictly controlled and there are few standards, so you generally have to qualify or translate a particular set of specifications before you can make valid comparisons. It is difficult enough to decipher and compare specifications on conventional audio equipment, but it gets to be very nebulous with wireless microphone systems. Add to this the fact that some manufacturers have actually published specifications that are wrong, which is an unforgivable marketing crime.

The performance of a wireless microphone system will vary dramatically from the test bench to the actual application in the field. The results of connecting test equipment directly to a receiver and measuring various performance specs will be very different than when the input signal to the receiver is generated by a weak radio signal coming from a transmitter several hundred feet away. It is safe to assume that the published specs for a wireless mic system are based on ideal RF conditions and a minimal transmitter to receiver distance.

You should always be skeptical of a spec that does not include the basis for measurement, or of a spec that is missing altogether. Anytime a particular spec is hard to interpret or is missing, it is a safe bet that the manufacturer might be trying to disguise the poor performance. In a few cases, it could also be that the manufacturer simply overlooked including the spec in the published literature. We at Lectrosonics would like to say that we never forget anything as important as a spec, but let’s face it, we’re human too. So, if you don’t see something on the published literature, please call us. We’d be glad to tell you more than you ever wanted to know about what’s missing.

SENSITIVITY

Good: 1uV for 20 dB SINAD

Excellent: 0.5 uV for 20 dB SINAD

This spec refers to the RF input level at the receiver required to produce a certain signal to noise ratio. Signal to noise performance in a receiver can be measured or rated several ways, but the most common methods are “SINAD” and “S/N RATIO.”

Here are six examples of sensitivity specifications as they would appear in various manufacturers literature. Curiously enough, all of these measurements were made on the same receiver.

0.34uV input for 12dB SINAD

0.30uV input for 12dB quieting

0.27uV input for 12dB S/N

0.45uV input for 20dB SINAD

0.47uV input for 30dB S/N

1.20uV input for 50dB S/N

All of these measurements can be called “sensitivity,” yet they actually measure different aspects of the receiver’s performance. Obviously it is necessary to compare “apples to apples” when making sensitivity comparisons. The above list shows how the sensitivity seems to vary depending on how the measurement is

made. The above measurements were all made with an “A” weighting filter to approximate the ear’s response to the noise. Most manufacturers will use this filter since it improves the measurements by 3dB to 6dB.

SINAD is a measurement that approximates the audible background noise heard along with a continuous signal at weak RF levels. SINAD is measured by running the system at full deviation with a weak RF signal and measuring the level at the receiver output which consists of signal + noise + distortion. Then a second measurement is made after electronically subtracting the audio signal (while the system is still running) and measuring the remaining noise and distortion. The first and second measurements are then expressed as a ratio. SINAD is probably the most consistent sensitivity measurement at low levels of RF, since it effectively removes the compandor from the circuit. Since the SINAD measurement is made with the system in actual operation at full deviation, it is more realistic than a simple signal to noise ratio measurement.

$$\text{SINAD} = \frac{\text{Signal} + \text{Noise} + \text{Distortion}}{\text{Noise} + \text{Distortion}}$$

S/N RATIO is a measurement that approximates the background noise heard during pauses in speech when the system is operating at a given RF level. It is another valid comparison of sensitivity. It is listed as the amount of RF signal required to produce a certain S/N figure, often 50dB. The 50dB S/N ratio is representative of a minimum usable sensitivity and corresponds to what a non-critical listener would accept. S/N RATIO is determined by measuring the system at a given RF signal level at full modulation, with maximum receiver output, then turning off the audio modulation and measuring the remaining noise. This will produce the RF signal level required for a given signal to noise ratio. This is the sensitivity rating of the receiver based upon signal to noise ratio.

The problem with this method of measurement is that the compandor will make the number twice as good as it really is. SINAD is really the better method to rate a receiver, but it does not produce numbers that look as good as S/N RATIO.

AUDIO DISTORTION

Good: Less than 1% at 1KHz

Excellent: Less than 0.5% at 1KHz

Generally these numbers are straightforward and can be compared directly. The distortion figures are usually taken at 1kHz. This is kind of a “best case” frequency since the compandors add distortion at lower frequencies, and narrow-band IF filters can add distortion at higher frequencies. Distortion at 100Hz can be 2.5% in a system that claims 0.4% at 1KHz.

DYNAMIC RANGE

Good: 90dB

Excellent: 105dB

This number should be a straightforward measurement but some manufacturers include the limiter dynamic range and/or the gain control range also. Sometimes this is done because it is cheaper to print better numbers than it is to design a superior product, but this can also be self-defense against someone else's "better" numbers. Remember that the dynamic range measurement is based on a minimal transmitter to receiver distance in a wireless mic system. When the same measurement is made with the transmitter 50 feet or more away from the receiver, this number will be significantly lower.

AM REJECTION

Good: 50dB at an unspecified RF level

Excellent: 60dB over a range such as 20uV to 50mV

This measurement shows how well the receiver rejects amplitude modulation (AM) of the RF signal caused by such things as fluorescent lamps, bridge rectifiers in other electronic equipment, SCR light dimmers and similar power circuits. This measurement, if given at all, is usually made at one RF level (the level that produces the best numbers of course) but should be made over a wide range since the real world is rarely so kind as to present an optimum RF level to the receiver.

IMAGE REJECTION

Good: 80dB

Excellent: Greater than 100dB

In the mixer stage of all wireless receivers there are two frequencies that will produce the IF frequency, and as far as the mixer is concerned, either frequency is equivalent. These two frequencies are equally spaced on either side of the oscillator frequency. For instance, if the IF frequency in the receiver is 10.7 MHz and the transmitter frequency (the carrier) is 179 MHz then the local oscillator frequency in the receiver will have to be 168.3 MHz ($179.0 - 168.3 = 10.7$ MHz). This receiver will have an image frequency at 157.6 MHz, because the difference between 157.6 and the local oscillator at 168.3 is also 10.7 MHz ($168.3 - 157.6 = 10.7$). If it weren't for the RF filters in the front end of the receiver, the receiver would be just as sensitive to the image frequency at 157.6 MHz as the "correct" frequency of 179 MHz.

Since the image frequency of 157.6 MHz is in the taxicab service band and taxicabs are allowed 75 Watts of power (wireless microphones typically only 0.05 to 0.10 Watts), the receiver in this example must do an outstanding job of rejecting the image frequency. Image rejection is a function of the front-end selectivity of a receiver and the IF frequency in the receiver. The image frequency is always twice the IF frequency below the carrier for low side oscillator injection and twice above for high side injection. The higher the IF frequency then the farther the image frequency is from the carrier and the easier it is to reject it in the front end RF filters. Better UHF receiver designs are using IF frequencies of 71 MHz up to 250 MHz and perhaps even higher in the future.

SPURIOUS REJECTION

Good: 80dB

Excellent: Greater than 100dB

This is very similar to image rejection, but measures how well the receiver rejects the entire range of frequencies that can be applied to the receiver by any outside source. Ideally the manufacturer will have tested the receiver from audio frequencies to microwave frequencies. This number measures how well the first RF section, the IF filters and other sections reject interfering signals.

THIRD ORDER INTERCEPT

Good: -15dBm

Excellent: +1dBm or higher

A high third order intercept spec is a desirable receiver specification since it measures how well the receiver resists interference caused by multiple interfering frequencies. Interfering frequencies may be other wireless microphones that are being used in the same location, or combinations of outside transmitters. This specification gives a single, excellent measure of how well the receiver resists many kinds of overload.

Consider transmitters on frequencies A and B, and a receiver on frequency C. If the three frequencies are equally spaced, the second harmonic of one of the transmitters will mix with the fundamental of the other transmitter, producing a signal exactly on the frequency of the receiver.

If: $(A \times 2) - B = C$ or $(B \times 2) - A = C$

Then: the receiver will likely respond to this third order IM.

As an example, consider transmitters on 181 MHz and 182 MHz. These will produce third order interference for receivers on either 183 MHz or 180 MHz.

$$(181 \times 2) - 182 = 180$$

or

$$(182 \times 2) - 181 = 183$$

Notice that the transmitter frequencies we chose are very close to the receiver frequency. This means that the selectivity of the receiver is largely useless. However the better the design of the RF stage and mixer, the less of this intermodulation interference will be produced. You can of course pick transmitter frequencies that will not produce interference with a specific receiver, but this gets to be very difficult in large, multi-channel systems. Additionally, in some urban areas there can be hundreds of high powered transmitters around you, over which you have no control. The receiver must have a high 3rd order intercept specification.

LIMITER RANGE

Good: 15dB

Excellent: 30 dB or more

This indicates the amount of audio overload the transmitter can handle before audibly distorting the signal. A good limiter allows the gain of the transmitter to be set higher, since not as much headroom has to be allowed to prevent audio overload. This important feature is found on only a few wireless systems, and provides an audible improvement in signal to noise ratio.

BATTERY LIFE

Good: 8 hours (5 hours with UHF models) alkaline 9 Volt

Excellent: 12 hours (8 hours with UHF models) alkaline 9 Volt

In some applications, a transmitter must operate for extended periods of 6 hours or more. If the transmitter quits before the session is complete, obviously someone is going to have a problem. In some cases, the cost of re-doing the session or performance could be significant. It is also very important that some means of evaluating the battery status be available. A "warning time" of an hour or more is generally useful.

In other applications, the cost of batteries can be an important consideration. If the transmitter is used for twelve hours a week and has a battery life of 6 hours, it can amount to \$250 a year, which is not a negligible sum for some budgets. (using a price of about \$2.49 per battery at 12 hours per week)

SPURIOUS EMISSIONS

Good: 50 dB below the carrier

Excellent: 60 dB below the carrier

Some wireless transmitters produce frequencies other than the desired carrier. All crystal controlled transmitters start with a low frequency crystal and multiply up to the carrier output frequency. For example, starting with a 15 MHz crystal controlled oscillator, the next stage would be a tripler to 45 MHz, then a doubler stage to 90 MHz, then a doubling output stage to produce the final frequency of 180 MHz. Many low level spurious frequencies are produced in this process, but the frequencies most likely to cause problems are at the carrier frequency plus and minus the internal crystal fundamental. In the example given they would be 180 MHz plus or minus 15 MHz. Spurs would be produced by this example at 165 MHz and 195 MHz. If there were another receiver at 195 MHz in the same location, it probably would pick up the spurious frequency.

TRANSMITTER OUTPUT POWER

Good: 30 mW for VHF and UHF models

Excellent: 50 mW for VHF; 100mW for UHF models

If there is any single specification that is most abused, it is this one. 50 mW (0.05 Watts) is the maximum output power allowed by the FCC for use in VHF wireless microphones. UHF transmitters are allowed up to 250 mW, but at this power level, battery consumption becomes a factor to consider.

The more power the transmitter radiates, the smaller the chances are for interference and the greater the operating range. There is a suitable "trade off," however, between output power and battery life. Some well known UHF transmitters really put out as little as 10 mW, so it is wise to look at both power output and battery life (or power consumption) when you compare specs from different manufacturers.

A listing in the published specs of a particular transmitter that states that the power is less than the FCC maximum, or one that simply states the FCC allowance itself, is meaningless. All legal transmitters meet the FCC requirement, but the best performance will come from those that put out a true 50 mW in the VHF spectrum, and 100 mW (or more) in the UHF spectrum, and offer battery life long enough for the particular application.

EVALUATING WIRELESS MICROPHONE SYSTEMS

In spite of the occasional complexities of operating a wireless microphone system, there are some simple tests that can be performed (without test equipment) that can be very revealing.

A wireless microphone is still a “microphone” by definition. Its sole purpose is to produce accurate audio for whatever application. The fact that it is “wireless” simply means that it can perform without an attached cable.

The following tests are recommended to help you assess the quality of a particular wireless mic system before you make the decision to buy or rent the system. Each of the tests will check the system for a particular type of performance and/or problem. In order to gain an overall assessment of the system quality, it is best to conduct as many of these tests as possible, if not all of them, since you will find that some designs are very good in some areas and poor in others. One or two tests alone is not enough to gain a good overall assessment.

THE “CAR KEY TEST”

This is a favorite amongst high-end wireless manufacturers. This simple test reveals how well a wireless mic system can handle high frequency audio transients and, in fact, the quality of the entire audio processing chain in the system.

Set up the wireless system with a pair of headphones or a sound system at a fairly high level without feedback. It is best to be able to listen to the audio output of the receiver away from the acoustic sound that the keys themselves generate. Set the input gain on the transmitter for a normal level with an average speaking voice.

Gently shake the key ring loosely near the microphone so that the keys jingle and rattle. Shake the keys within a foot or so of the microphone, then move them gradually away from the microphone while you shake them until they are as much as 8 to 10 feet away from the mic. Listen to the audio that comes out of the receiver. Does it sound like car keys, or a bag of potato chips being crushed?

Next, have someone talk into the wireless system while the keys are shaken as in the previous paragraph. Listen for distortion of the talker’s voice while the keys rattle. Move the keys from a foot or so from the microphone and then away from the microphone to as much as 8 to 10 feet and listen to the effect on the talker’s voice.

This is a tough test for anything other than a hard-wired microphone. The results you hear will tell you, without argument, how well the input limiter, and compandor attack and decay times work in the design, and give you a clear idea of the audio quality you can expect from the system in real life.

A loosely shaken set of metallic car keys on a key ring produces large quantities of high frequency transients. A wireless system that fails this test miserably, and a lot do, will also distort sibilants in the human voice. Often listeners don’t notice this high frequency transient distortion because sibilants don’t have a specific frequency but are more like random noise. Distorted random noise still sounds like noise. On a system that fails the key test, however, strong sibilants won’t have a clear, open quality but will instead have a muffled sound as if someone’s

hand has been put between the mouth and the mic. The key test will warn you to listen closely for the effect. The key test will also reveal audio circuits that are upset by supersonics. The peak energy of jangling keys is actually around 30 kHz, well above human hearing. If the circuits in the transmitter don’t filter out the supersonics, the compandor will respond grossly. This is a valid test since sibilants in the human voice also contain supersonics. Supersonic overload will cause sibilants to sound ragged as the level is driven up and down by sounds you can’t hear.

THE LOW FREQUENCY AUDIO “BUMP TEST”

This test will reveal the inherent signal to noise ratio of the wireless system and how well the compandor handles low frequency audio signals. The “inherent signal to noise ratio” is the signal to noise ratio before companding.

This test requires listening to the system in a very quiet environment with minimal background noise. Place the transmitter and microphone in a different room from the receiver, or use high isolation headphones to monitor the audio output of the receiver. In either case, there must be minimal background noise near the microphone. Background noise at a high enough level will negate the test.

Set up the system for normal voice levels, then place the transmitter and microphone on a table or counter. Make a fist with your hand and gently bump the table with the meaty part of your hand (not your knuckle). The idea is to generate a low level, low frequency “bump” near the microphone at just enough level to open the compandor on the wireless system.

Try varying how hard you bump the table with your fist to find a low level that just opens the compandor and listen to the results. When you “bump” the table, listen for background noise that sounds like a “whoosh” or “swish” that accompanies the sound of the bump.

The idea is to listen to how much background noise is released through the wireless system when the “bump” occurs, and also to whether or not the “bump” heard through the wireless sounds the same as in real life.

This is an excellent test of the difference between a single-band compandor and a dual-band compandor with DNR filtering, as well as a test of the signal to noise ratio of the wireless system. With the transmitter gain set for a normal voice level during this test, the results you hear will be what the system will actually do in real use.

It is also interesting, although not a valid test, to set the transmitter gain at minimum, then turn the receiver output up to maximum, and do the bump test again. The only reason to do this is to help understand just how much noise is actually suppressed by the system in normal use, and to emphasize the importance of proper transmitter gain adjustment.

A wireless mic system design that uses a large amount of pre-emphasis/de-emphasis as noise reduction will likely do fairly well in the “bump test,” however, it may also fail miserably in the previous “car key test.”

CHECKING THE INPUT LIMITER RANGE

In this test, you will need to make some loud noises at the microphone, but be able monitor the output of the receiver in a fairly quiet environment. It's best done with two people. The purpose of this test is to listen to how well the transmitter input limiter can handle audio peaks well above the average level.

Set up the wireless system for an average level so that the system indicates brief peaks at full modulation with a normal voice, with the microphone at a distance of 2 feet from the talker's mouth. While the talker speaks at a constant level, bring the microphone closer and closer to their mouth. Make sure breath pops don't get into the microphone when it gets close to the mouth by keeping the microphone to the side of their mouth. If the transmitter has a poor limiter, or no limiter at all, the signal will get louder and then begin to distort as the loudness increases. In a system with a good limiter, the sound will get louder up to the beginning of limiting, and then will remain at a fairly level volume even as the mic is moved closer to the mouth.

The character of the sound may change due to the different distances as the mic is moved closer to the talker's mouth, but the system should be able to handle a large overload without distortion. You can also test a limiter by shouting into a microphone, but keep in mind that the character of the talker's will change as they go from a speaking voice to a shout. Some wireless system designs try to prevent overload by having low microphone gain available to the user. This compromise will result in a poor signal to noise ratio when the RF signal gets weak. A sharp audio peak produced by hand claps or other means is also a good test of the limiter action.

THE "WALK TESTS"

As the name implies, this is a test where one person takes a walk while talking into the transmitter, and the other person listens to the receiver output.

There are two different "walk tests" for a wireless system.

- Check the maximum operating range
- Check the short range squelch and diversity performance

Before conducting either of these tests, the wireless mic system should be set up exactly the way it will be used. The microphone and transmitter must be in the exact position on the talker's body where they will be used, and the receiver must be connected to whatever equipment it will feed, with power and antennas connected and positioned as in actual use. Unless the wireless system is set up this way, the results of the walk tests will not be realistic. Do not remove antennas on the transmitter or receiver to try to simulate extreme operating range, as this will alter the way some receivers work, such as Lectrosonics models that use SmartSquelch™ and SmartDiversity™ circuitry.

Checking for Maximum Range:

The classic walk test is to see how far away you can get with the transmitter before dropouts are bad enough to make the system unusable. You can walk until a count of 8 to 10 dropouts occur, for example, and define that as the limit of the range. Or, walk until the dropouts or hiss buildup is objectionable according to your own assessment. When comparing two or more different wireless systems, it is very important to repeat the same exact path for each walk test, position the receivers and the transmitters

on the body in the same location with the same interconnections, and apply the same criteria to define the limit of the range, or it will not be a valid comparison.

Even if the maximum range of the system is well beyond what you would normally need, this test will demonstrate the sensitivity of the receiver and how well the system handles weak signal conditions in general.

Short Range Test of Squelch and Diversity Performance:

A "short range" walk test checks to see how well the receiver handles deep multi-path nulls that occur at a close operating range with a generally strong RF signal. Do not remove the antennas on the transmitter or receiver to worsen the conditions, as this will negate the validity of the test.

Set up the wireless system same as above, except find a location where multi-path reflections will be abundant, such as an area with lots of metal file cabinets or lockers, a medium to small metal building, a metal trailer, etc. Place the receiver antenna/s within a couple of feet or so of a metal surface to exaggerate multi-path cancellations at the antenna. The antennas on a diversity receiver need to be at least a 1/2 wavelength apart to achieve the maximum benefit of the diversity technique. If the receiver cannot be configured this way in actual use, then position the antennas as they will be used.

Walk around the area with the transmitter while speaking and try to find a location where a dropout or squelch (audio mute) occurs. Moving the transmitter around within a couple feet of a metal surface may help to generate a multi-path condition.

The idea in this test is to see how prone the system is to producing dropouts, and to look for loud noise bursts that occur during a dropout if and when one does occur. An effective diversity system will make it difficult to find a dropout, which will tell you something about the effectiveness of the diversity circuitry. If and when a dropout does occur with a strong average RF level at the receiver, the receiver should simply mute the audio during the dropout and not allow any noise or noise burst to occur.

An aggressive squelch system in the receiver is best in a close range situation, as it will eliminate noise bursts created by dropouts, however, it will also limit the maximum operating range as in the previous test. A less aggressive squelch allows maximum operating range, but will generally allow noise bursts to occur during dropouts at close range.

These two tests illustrate the dilemma of a conventional squelch system in having to choose between either close range or distant operating range, and also illustrates the benefit of an adaptive squelch system like the Lectrosonics SmartSquelch™ which automatically configures itself for close range or long distance operation as the system is being used. The tests are also a good proving ground for Lectrosonics SmartDiversity™.

After conducting both types of walk tests, you will have a good idea of what to expect in actual use. Some systems may provide excellent maximum range characteristics, but prove to be noisy in short range, multi-path conditions. Other systems may be great at the short range test, but be poor performers in the maximum range test. Of course, the ideal wireless system would do well in both tests.

THE “HARD-WIRED A-B TEST”

This is a matter of setting up two identical microphones, one connected with an audio cable and the other with a wireless system, to perform a listening test. The trick to this is to get the listening levels of both setups to be exactly the same. Even a very slight difference in level will “fool” the ears into hearing differences that may not actually exist.

Place the microphones equidistant from a sound source or someone’s mouth so the the same audio signal enters both microphones. Switch back and forth between the cabled and the wireless setup as the listener compares the sound of each setup. This, of course, is best done in a “blindfold” manner where the listener has no way of telling which setup is being monitored, and by writing down a few notes about the results.

As a “reality check,” it is always good idea to swap the microphones and listen to them a second time to see if there are slight differences in the microphones themselves that may have been detected in the first comparison.

GLOSSARY OF WIRELESS MICROPHONE TERMS

AM: Amplitude Modulated (carrier level shifts)

CARRIER: The operating frequency of a wireless system. A fixed frequency radio signal which is shifted up and down (modulated) in either frequency (FM) or level (AM) by the audio signal.

COMPANDOR: A noise reduction circuit which employs an encode/decode process. The transmitter encodes (compresses) the dynamics of the audio signal and the receiver decodes (expands) the dynamics of the audio signal. The compressor in the transmitter and the expander in the receiver must be perfectly complementary.

dB_i: Decibels of gain compared to an isotropic radiator.

dB_d: Decibels of gain compared to a dipole antenna

NOTE: dB_d is 3dB above dB_i

DETECTOR (DEMODULATOR): The circuit in a receiver which is used to recover the intelligence (audio) from a signal.

DIVERSITY: A method of reducing or eliminating multi-path dropouts by using two or more antennas and/or receivers. The most popular methods include dual-antenna phase switching, dual-receiver audio switching and “ratio diversity” audio combining. The most effective method is ratio diversity combining.

DROP OUT: A momentary loss of the carrier and sound, or a buildup of background noise when the transmitter is in a certain location in the room. Moving the transmitter (even a few inches) usually restores the sound to normal.

FM: Frequency Modulated (carrier frequency shifts)

FRONT-END: The first stage of filtering in a receiver. The first circuit stage following the antenna input to the receiver.

HIGH SIDE INJECTION: A superhet receiver design in which the oscillator frequency is above the carrier frequency.

IF: Intermediate Frequency. Refers to the resulting signal in a superhet receiver after the incoming carrier is mixed with the oscillator signal.

IM PERFORMANCE: A measure of the ability of the receiver to reject signals which are capable of producing IM products.

IMAGE REJECTION: A measure of the ability of the receiver to reject RF signals present on the image frequency of the receiver created by the mixer. Image rejection is one of the purposes of front-end filtering in a superhet receiver.

INTERMODULATION: Also referred to as “IM.” The mixing of two or more signals, producing sums, differences and harmonic multiples. IM generally occurs in the gain amplifier ahead of the mixer stage within a receiver, but also occurs in any non-linear device.

ISOTROPIC RADIATOR: A completely non-directional antenna (one which radiates equally well in all directions.) This antenna exists only as a mathematical concept and is used as a theoretical reference to measure antenna gain.

LOW SIDE INJECTION: A superhet receiver design in which the oscillator frequency is below the carrier frequency.

MIXER: The circuit or component in a superhet receiver where the oscillator signal is combined with the incoming carrier signal.

MULTI-PATH: The presence of multiple signals arriving at the receiver antenna simultaneously. Signals that are in phase will add to one another. Signals that are out of phase will cancel one another.

OSCILLATOR: An electronic circuit which generates a signal at a specific frequency.

RECEIVER IMAGE: A second frequency that a superhet receiver will respond to. The image frequency is two times the IF frequency either above or below the carrier frequency, depending upon whether the receiver design is “low side” or “high side” injection. An RF signal on the “image” frequency of the receiver will produce a difference signal in the mixer just as valid as the intended IF signal created by mixing the oscillator with the carrier.

RECEIVER: The device that picks up the radio signal from the transmitter, converts it into an audio signal and feeds audio into your sound system or recorder.

RF NOISE: Radio signals generated by something other than the transmitter. Usually sounds like hiss, static or hash. RFI (Radio Frequency Interference) may be AM or FM, but the effect is that it either alters the audio signal, or adds background noise to the audio signal.

RF: Radio Frequency. Also used generally to refer to the radio signal generated by the system transmitter, or to energy present from other sources that may be picked up by a wireless receiver.

RFI: Radio Frequency Interference. A non-desired radio signal which creates noise or dropouts in the wireless system or noise in a sound system. RFI can be generated by a wide variety of sources including electronic organs, computers, switching power supplies, broadcast radio signals and outside radio devices. Radio signal energy can enter a sound system component or alter the audio signals in cabling, producing annoying hiss, whining or intelligible audio signals. Proper shielding and balanced audio cabling are the best defense against RFI problems in a sound system. High quality receivers are the best defense against RFI in wireless microphone systems.

SELECTIVITY: The ability of a receiver to reject interfering signals close to the desired carrier frequency.

SENSITIVITY: The ability of a receiver to operate on very weak RF signal levels.

SQUELCH: A muted, or silent, condition in the receiver. When the radio signal from a transmitter is too weak to produce a quality audio signal, the receiver will shut off or “squellch.” “Squellch” is also used to refer to the circuit in the receiver that provides the audio muting.

SUPERHET: Short for “super-heterodyne.” The mixing of two signals producing a third signal. Wireless microphone receivers (and almost all other receivers) utilize an oscillator, producing a signal which is mixed with the incoming radio signal from the receiver antenna to produce a lower frequency signal (the IF signal).

SUPERSONIC NOISE SQUELCH: A fairly popular method of muting the audio output of a receiver when the supersonic noise reaches a preset level. The assumption is that noise buildup above the audio passband (20 to 30KHz range) is an indication that the signal to noise ratio of the system is inadequate to produce a usable audio signal.

THIRD ORDER INTERCEPT: A measure of how well the receiver resists interference caused by multiple interfering signals. This specification gives a single, excellent measure of how well the receiver resists many kinds of overload. It is directly related to the RF compression level.

TRANSMITTER: The device worn (or held) by the user which sends or “transmits” the sound from the microphone to the receiver. The transmitter actually converts the electrical signal coming from the microphone into a radio signal and then “transmits” it out through some sort of antenna.

UHF: Ultra High Frequency (generally 300MHz to 3000MHz)

VHF: Very High Frequency (30 to 300MHz)

High Band wireless systems are usually 150MHz to 216MHz

Low band wireless systems are usually 30MHz to 50MHz

WIRELESS MICROPHONE APPLICATIONS

FREE-LANCE SOUND AND VIDEO PRODUCERS

There are thousands of “free-lance” video producers across the US. Most of these producers are individuals who contract with teleproduction companies, networks, ad agencies or corporate clients for video and audio production services. Most free-lance producers are geared for field production, with limited post production services.

A unique type of multi-channel wireless audio system has emerged in free-lance use that is often called a “bag system.” This is a portable rig in an over-shoulder carrying case that contains several wireless receivers, a portable mixer, one or two wireless transmitters connected to the output of the mixer, a boom pole with mic and cabling, a variety of audio adapters, walkie-talkies, a tape recorder and sometimes even spare batteries for the videographer. It’s an awfully busy little kit, and a tough environment for wireless.

The audio output of the mixer is fed to one or two transmitters that send the signal to the camera receiver/s so that the whole video/audio rig is completely portable. This is the technique used for the vast majority of television documentary production in the field.

The primary challenge for wireless operation in a bag system like this rests in the fact that the mixer output transmitters are often within inches of the receivers in the bag. It is never a good idea to place transmitters and receivers this close together in any multi-channel wireless system, however, there is no other choice to attain this level of portability for field production. The check-out procedure outlined in the INTERFERENCE section of this guide is mandatory to ensure reliable operation.

Since the whole purpose of a bag system is portability, it goes without saying that the system will constantly be moved from one location to another, often from city to city. Thus, interference from television broadcast signals and a myriad of other sources cannot be predicted. This means that the only way to get a rig like this to work reliably is to use very high quality receivers with excellent selectivity and IM performance, and make a habit of checking out the system thoroughly with each new location. It’s not easy, but this is how it’s done.

BROADCAST NEWS GATHERING (ENG)

The rough and tumble, mad scramble of gathering the news is no place for a wimpy wireless. The receivers must be compact and portable for mounting on video cameras, and the transmitters must be rugged enough to withstand the physical abuse that is the very nature of this environment. The RF link has to work on the first try, since there is no time to re-assemble everyone and re-shoot the scene. This might explain why very few companies make wireless systems that provide reliable operation for ENG.

Most ENG crews use only one or two wireless systems at any given moment, which eases the complexities of operating the wireless systems, somewhat. There is, however, rarely time to go through any check-out procedures, so only the most selective, high performance receivers will work reliably.

Plug-on transmitters are the primary choice of professional ENG crews, due to the versatility they provide to meet varying microphone requirements for each shot. The best designs can be

used with a wide variety of lavalier, hand-held and shotgun microphones, and feature a convenient input coupler that is easy to use, but provides a secure attachment for the microphone.

As cameras become smaller, the size of a receiver that can be mounted directly on a camera must also be small. Modern video cameras (especially digital models) radiate RF noise, which can also limit the choices of receivers that can be mounted on the camera. Only receivers with very high selectivity can reject the RFI from the camera and retain usable operating range. Once again, receiver selectivity is king.

WORSHIP CENTERS

With well over 450,000 worship centers in the USA alone, this is perhaps the largest market for wireless microphone systems. While the types of services provided by various worship houses vary substantially, the way they use wireless mic systems is fairly consistent. Applications in worship centers can require lavalier and/or hand-held transmitters to make various parts of the worship services more effective.

Worship centers are “predictable” users, since worship services are normally offered on a regularly scheduled basis in the same location. Weddings, funeral services and other types of gatherings can occur at varying times, but most of the usage is scheduled in advance. Some worship centers are concerned about the cost of batteries used to operate the wireless transmitter, while others are more concerned that the batteries may fail during use, causing a disruption of the service. In either case, however, the usage is still predictable and planned in advance, in contrast to some applications, such as news gathering, where the wireless usage is with little or no notice and almost always in a new location.

The acoustic environment in most worship centers is usually very quiet, with a closely attentive listener, and generally with a good quality sound system. This makes even subtle problems in the wireless system very obvious to the listeners. All of this demands that the wireless system provide a very high signal to noise ratio, excellent audio quality and a strong resistance to interference and dropout problems.

In some types of services, the RF environment can become more difficult if the services include extensive use of electronic musical instruments. Strong RF energy can be radiated from many types of electronic synthesizers, organs, and other electronic instruments, generating enough RF noise to cause problems with dropouts and operating range in the wireless mic systems. A walk-test of the wireless system with everything turned on should always be performed any time electronic musical instruments are to be used with the wireless, especially when new electronics have been added to the sound system.

Budget and cost considerations are always a concern for worship centers. Finding the right balance between cost and the necessary performance is not difficult to determine, it just takes a little thought in the beginning. It is always good practice to install the highest quality wireless mic system the budget will allow, even if it means waiting a bit longer for the purchase.

MOTION PICTURE PRODUCTION

Motion picture productions represent one of the most prestigious, yet demanding applications for wireless microphone systems. The techniques used for recording audio for film have also changed from earlier years. Dialogue is now recorded live in the scene, “sweetened” or modified in post-production and then synchronized with the picture in the composite mix. In years past, the final audio was often overdubbed in post-production, using the audio recorded on the set as only a reference for re-recording.

With the advent of high quality wireless microphone systems, the need for over-dubbing the actors’ dialogue in post production has largely disappeared. The audio captured during the filming is used for the final track, placing an acute demand on the wireless systems to deliver outstanding audio quality.

The demand for very high quality wireless mic systems in the film business is due in part to the excessive cost of re-shooting a scene. A single scene lasting only a few seconds can easily cost thousands of dollars to produce. If the wireless mic system drops out and the scene has to be re-shot, or the audio has to be overdubbed in post-production, it can be quite expensive. Another reason for the demand for high quality, high reliability wireless mic systems is due to the fact that modern theaters are equipped with high quality sound systems. Most people also now own or often listen to high quality sound systems in their homes, often with a digital signal source. The average consumer or movie goer has been trained to expect higher quality sound.

With the advances in signal processing over the last few years, there is a growing desire in many post-production engineers to utilize close miking techniques in the field, and then modify the audio later to make it “fit” the picture. The sound of a person’s voice will vary greatly depending upon how much ambient noise, echo and reverberation is included in the mix. For example, it is easy to tell if the sound of someone’s voice is in a large room (like a warehouse) or a small room by simply listening to the amount of background noise and echoes. It is easy to make a person’s voice sound like it is outdoors, in a large room, etc. through equalization and by adding additional background noise, echoes and reverberation, but it is very difficult, if not impossible, to remove background noise and echoes if they are contained in the original recording. Wireless mic systems are used extensively in motion picture production since they make close miking techniques easy to accomplish. In some cases, the location sound mixer may include background noise in the scene to make the sound “fit” the picture better.

Wireless mic systems must interface with many types of other devices on a typical film production set. For example, fishpoles and “plant” mics are being used with wireless transmitters, which takes less time to set up than the cabled equivalents. Production sound mixers require a variety of different types of microphones for various applications and voice types, and often have personal preferences with regard to which microphone capsules are best. Thus, it is imperative that a wireless system for film production be capable of working with all popular types of microphone capsules. Accurate level metering on the transmitter also comes in very handy when the receiver is not within sight.

THEATRE

The performing arts includes several applications for wireless microphone systems. A prime example is theatre, which is normally a multi-channel wireless application. A stage production is rehearsed in advance, which helps check out the wireless system, but it is actually performed live in front of an audience, so reliable performance of the wireless system is often more critical than in a recorded event. Some theatre applications are virtually permanent installations where the production always occurs in the same facility. Other theatre shows travel around the country, which makes operating a multi-channel wireless system far more complicated. Some of the larger traveling theatre shows employ full time staff to set up and operate the wireless microphone systems.

The most effective and practical wireless receiver systems for theatre are rack mounted assemblies, using antenna and power distribution systems. Frequency coordination is a must in any multi-channel application, but it is an on-going battle in a traveling show. Intermodulation between the wireless systems themselves is always a concern, but usually it can be avoided or minimized through proper frequency coordination and careful installation. Interference from external sources, however, becomes almost inevitable if the show is traveling. The only type of wireless systems that should be used for theatre are very high performance systems using high selectivity receivers.

SOUND STAGE

“Sound reinforcement companies,” or what might be called “touring companies,” are prominent wireless microphone users in the public eye, even though they represent a relatively small market in terms of the number of wireless systems used. Large touring companies are highly visible due to the fact that they often produce the audio for nationally televised performances and major musical groups. The applications for wireless systems in this market generally range from hand-held transmitters for singing, to belt-pack models for musical instruments.

Touring companies that work on a national or international basis face difficult frequency coordination problems as they travel across the country or around the world. Touring companies that work on a local or regional basis may not face as many problems with frequency coordination or reliability, but the sound quality is still just as important as in a major telecast or concert.

On a sound stage, the receiver antenna/s can usually be placed close to the transmitters. This helps to overcome the problem of dropouts, and can even help to reduce interference from external sources in the vicinity, but the problems generated by RF noise sources on stage (digital instruments and signal processing) can still create major problems.

All major productions involve detailed frequency coordination and testing before the production begins. The venue where the production occurs will usually have more radio devices in use than just the wireless mics used on stage. There will invariably be communications radios and often a wireless intercom system in use at a major production. The operating frequencies and intermodulation of all the radio devices must be taken into account before there can be any reasonable assurance that all the systems will operate reliably. High selectivity receivers are a must in this type of application.

Most sound reinforcement applications consist of a “musical format.” With respect to musical formats, there are several basic types of venues:

Concerts

At a live concert, the production is with a large audience, and is often televised as well. It is critical that the wireless systems be as reliable as possible since there is no chance to go back and do a particular scene over again. The sound system is operated manually, so the squelch capabilities of the receivers are usually not critical, since the channel is manually muted on the console when a particular wireless system is not in use. Most concerts involve multi-channel wireless systems, which means that the receiver must exhibit outstanding selectivity and IM performance. Specialized antennas, multi-couplers and other equipment for multi-channel systems will commonly be used. In addition, computer interfaces for the wireless systems can be very helpful to bring remote control and monitoring to a convenient location, which is often away from the receiver rack.

The receivers feed sound into very high output PA systems, making the signal to noise ratio of the system a critical design consideration. Since the systems are normally used for singing and musical instruments, the input overload capabilities of the transmitter are also very important.

One of the most problematic situations that occurs with touring companies producing concerts is the matter of frequency selection and coordination. Since the concert is almost always a “one shot deal,” there is rarely an opportunity to re-work the frequency coordination plan after a live concert has started. Intermodulation is highly complex and it is absurd to try to switch frequencies on a problem system after the program has started. By switching frequencies on one system to solve an RF problem, several new problems could easily be generated on other wireless systems. Frequency switchable receivers and transmitters offer little or no help once the show has started.

The frequency of one wireless system cannot be changed without considering the implications it could have on other systems. Frequency changes can only be made between shows when there is time to also work on the overall frequency coordination plan. A major touring company will normally have “spare” wireless systems on coordinated frequencies ready and waiting if a problem occurs.

Night clubs

While sound quality is no less critical in a night club than at a concert, night clubs can have a distinct advantage. If the contract is for the same band and sound company to produce a number of similar shows on the same stage over a period of several days or weeks, wireless problems can be resolved with predictable results, since the location often remains unchanged between shows.

Traveling Evangelists

Another application for wireless systems in sound reinforcement is with traveling evangelists. The venue in this application usually involves lavalier systems for speaking, hand-held systems for singing, and belt-pack systems for musical instruments. Multi-channel wireless systems with as many as 10 channels are often used. The stage will often include a variety of musical instruments, such as synthesizers and MIDI controlled keyboards and percussion sets, electric guitars, power amplifiers, monitor

speakers and so on. In many cases, a sound company will contract to travel with the evangelist on a larger venue just as they would with a band.

A traveling evangelical production is generally the same as a concert with respect to the equipment used to stage the production. The sound system is normally a high output PA system, the production is staged live, with many of them televised live or recorded for later broadcast. The requirements for wireless microphone systems in this application are the same as any large scale concert, and the RF environment is every bit as difficult.

CORPORATE APPLICATIONS

Corporate television production

Many medium to larger sized companies have departments whose sole function is to produce video tapes for either advertising or training. The cost of producing the video tapes internally versus the cost of hiring them done outside of the company, and the decreasing cost of quality video equipment, has given rise to many programs being produced internally. The corporate user may either rent or purchase wireless systems, depending upon how often they need to use them.

The corporate video user utilizes wireless microphone systems to produce recorded materials. This lessens the importance of the wireless system reliability, since a scene could oftentimes be shot again if there were problems, but the inconvenience of having to reshoot a scene still outweighs a slightly higher cost of a high quality wireless.

Corporate Trainers

There has always been a need for wireless microphone systems for use by traveling “trainers” in the corporate market. These are either company employees or hired professional speakers who travel across the country or around the world giving lectures or conducting training seminars to groups as small as 20 or 30, or to groups as large as several hundred. The use of a wireless system, which enables them to also use other visual aids, has become a standard requirement.

A wireless system for a traveling “trainer” must operate in a wide variety of geographic locations without interference. The receiver in the system must usually provide enough audio outputs to accommodate both sound system feeds and recorder feeds. Since the trainers must travel, size and weight are also a major factor in choosing an appropriate system to meet their needs. It is often convenient for the receiver to be battery powered, so that the presenter can locate the receiver near the audio input jacks to the house sound system without having to run long power cords, or carry long audio cables with them as they travel. The same, compact receivers commonly used in field production prove to be very useful for travelling presenters and public speakers.

WEDDING AND EVENT VIDEOGRAPHERS

Videotaping weddings has become as common as photographing weddings. While it would seem logical for photographers to begin to include video production in weddings, this is generally not the case. This means that at a wedding there will often be both a video company and a photographer working. The video production must also include audio which can create some annoyances for the photographer, such as microphone cables, clip-on mics, etc. A wireless microphone system not only improves the audio quality, but it also makes it easier for the video crew and photogra-

pher to work together (no cabling on the floor, and so on). A belt-pack transmitter that works with almost any type of mic will permit the use of special lavalier models designed to be concealed. Most entry level wedding videographers begin offering their services with consumer level video products. Most of this is due to the cost of the equipment, and the fact that many wedding videographers only shoot weddings on a part-time basis, while keeping full-time jobs elsewhere. In addition, the cost of a very high quality video production of a wedding (multiple cameras and separate sound mixer) makes it impractical for most wedding budgets. The videographer can rarely charge enough for their services to permit the use of professional and broadcast level equipment. This presents a curious paradox. On one hand, a wedding application dictates a very high quality wireless system, since they can't go back and do it over again. On the other hand, however, it is difficult to justify the cost of broadcast quality equipment because of the limited budgets typical of weddings.

Audio lost in the production due to a wireless problem at a wedding cannot be re-captured conveniently. Even though, in theory, the exchanging of wedding vows could be re-enacted, it would certainly not gain any points for the producer with the bride, the groom or either of their families. This points to the importance of prior planning and the use of high quality wireless systems. Since most weddings occur in worship centers, it is also very important to coordinate the wireless systems used for the video production with those used in the worship center. This includes a thorough walk-test and check out before the ceremony starts, with all of the wireless systems in place and turned on as they will actually be used during the ceremony.

In a multiple camera production, it makes sense to use a single transmitter with a matching receiver on each camera. In more advanced productions, multiple wireless mic systems will be placed appropriately, with the matching receivers in a central location feeding an audio mixer. The output of the mixer can then be fed to one or more wireless transmitters to radio the mixed audio back to the camera or cameras. This sort of setup, of course, requires the same advance planning and check out as any multi-channel wireless system. A recorder can also be used at the mixer location to capture a redundant audio track that can be useful if a problem occurs with the wireless feed to the cameras during the ceremony.

SPECIALIZED APPLICATIONS

Other applications for wireless microphone systems include:

Auctioneers use wireless microphone systems extensively, since they require the mobility that wireless affords. Most of the wireless systems sold into the auctioneering market are part of complete portable sound systems, normally used with headset type microphones for hands-free use.

Band Directors use wireless microphone systems for marching band rehearsals and on the field during performances. The wireless systems used for rehearsals are normally combined with some type of portable sound system. The wireless transmitters used during performances can range from belt-pack transmitters mounted on instruments to hand-held transmitters that feed receivers connected directly into the house or stadium sound system.

Magicians make up a small, but interesting market for wireless microphone systems. In many cases, a magician will conceal a microphone inside a variety of different costumes, which means that they require a versatile transmitter that will adapt to a wide variety of microphones. In most cases, magicians travel to different events, so the physical size and RF performance of the receiver is a concern. Most magicians prefer to "travel light," so a compact receiver would be preferred. Interference is always a concern for travelers, so the selectivity and IM suppression performance of the receiver are important considerations.

Bingo Halls are usually multi-million dollar operations with budgets that can easily afford the convenience of wireless. Bingo Halls use wireless microphones for the staff members who walk the floors to verify the bingo cards at the end of a game. Generally speaking, a bingo hall needs multiple transmitters, but never needs to run more than one of them at a time. The most cost-effective wireless systems for them include a single receiver with multiple "push to talk" transmitters.



581 Laser Road, Rio Rancho, NM 87124 USA

Phone (800) 821-1121 or (505) 892-4501

Fax (505) 892-6243

E-mail: sales@lectrosonics.com

Web site: lectrosonics.com

Inovative audio since 1971